

Axial piston variable pump

A15VSO, A15VLO series 10

RE 92800

Edition: 10.2013

Replaces: 08.2013

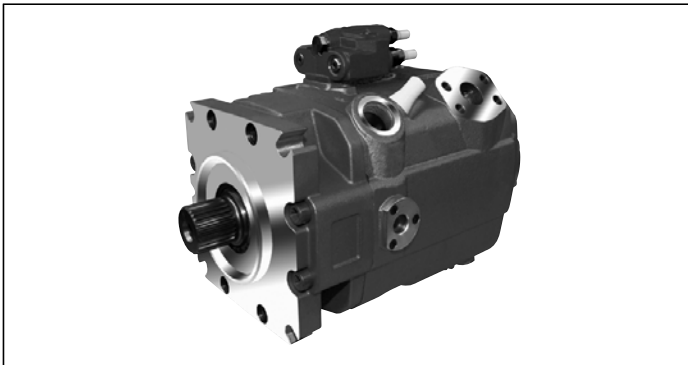

- ▶ Sizes 110 to 280
- ▶ Nominal pressure 350 bar
- ▶ Maximum pressure 420 bar
- ▶ Open circuit

Features

- ▶ Variable axial piston pump of swashplate design for hydrostatic drives in open circuit.
- ▶ For use preferably in stationary applications.
- ▶ The flow is proportional to the drive speed and displacement.
- ▶ The flow can be infinitely varied by adjusting the swashplate angle.
- ▶ The pump can work either self-priming or with a charge pump.
- ▶ A wide range of highly adaptable control devices with different control and regulating functions for stationary applications.
- ▶ 100% mooring function possible depending on specific controller (swivel mode, operation as a motor).
- ▶ The universal through drive is suitable for adding gear pumps and axial piston pumps up to the same size, i.e. 100% through drive.
- ▶ Compact design
- ▶ High efficiency
- ▶ High power density
- ▶ Low noise level

Contents

Ordering code	2
Hydraulic fluid	5
Shaft seal	6
Charge pump (impeller)	6
Operating pressure range	7
Technical data	8
Power controller	11
Stroke control	15
Pressure controller	22
Dimensions size 110	26
Dimensions size 145	30
Dimensions size 175	34
Dimensions size 210	39
Dimensions size 280	44
Through drives dimensions	49
Overview of attachment options	53
Combination pumps A15V... + A15V...	54
Connector for solenoids	55
Installation instructions	56
General instructions	58

Ordering code

01	02	03	04	05	06	07	08	09	10	11	12	13	14	15	16	17	18	19	20	21	
A15V									/	10	M					1			0	-	

Axial piston unit

01	Swashplate design, variable, nominal pressure 350 bar, maximum pressure 420 bar	A15V
----	---	-------------

Operating mode

			110	145	175	210	280	
02	Pump, open circuit	without charge pump	●	●	●	●	●	SO
		with charge pump	-	○	○	○	○	LO

Sizes (NG)

03	Geometric displacement, see technical data on page 8	110	145	175	210	280
----	--	------------	------------	------------	------------	------------

Control devices: basic controller¹⁾

					110	145	175	210	280	
04	Power controller	fixed setting			●	●	●	●	●	LR
		Override	electric-proportional	negative control	$U = 24 \text{ V DC}$	●	●	●	●	●
	Summation power controller	override hydraulic-proportional, high pressure	negative control	with stop ²⁾	●	●	●	●	●	CR
				without stop ³⁾	○	○	○	○	○	PR
	Stroke control ⁴⁾	electric-proportional	positive control	$U = 24 \text{ V DC}$	●	●	●	●	●	E2
			electric, two-point	positive control	$U = 24 \text{ V DC}$	●	●	●	●	●
		hydraulic-proportional, pilot pressure	negative control	$\Delta p = 25 \text{ bar}$	●	●	●	●	●	H3
			positive control		●	●	●	●	●	H4
	hydraulic-proportional, pilot pressure	negative control	$\Delta p = 35 \text{ bar}$	●	●	●	●	●	H5	
		positive control		●	●	●	●	●	H6	
	Pressure controller with one-side swiveling	fixed setting			●	●	●	●	●	DR
		hydraulic remote controlled for parallel operation	positive control		●	●	●	●	●	DG
positive control				●	●	●	●	●	Dp⁵⁾	
Pressure controller with mooring function	fixed setting			○	○	○	○	○	MD⁶⁾⁷⁾	

Additional controllers: pressure controller¹⁾

					110	145	175	210	280	
05	Without additional controller (without symbol)				●	●	●	●	●	
	With one-side swiveling, fixed setting				●	●	●	●	●	DR
	With one-side swiveling	hydraulic remote controlled for parallel operation	positive control		●	●	●	●	●	DG
			positive control		●	●	●	●	●	Dp⁵⁾

Additional controllers: stroke control or unloading¹⁾

					110	145	175	210	280	
06	Without additional controller (without symbol)				●	●	●	●	●	
	Stroke control ⁴⁾ Can be combined with basic controllers Lx, CR, PR	electric-proportional	positive control	$U = 24 \text{ V DC}$	●	●	●	●	●	E2
			electric, two-point	positive control	$U = 24 \text{ V DC}$	●	●	●	●	●
		hydraulic-proportional, pilot pressure	negative control	$\Delta p = 25 \text{ bar}$	●	●	●	●	●	H3
			positive control		●	●	●	●	●	H4
	hydraulic-proportional, pilot pressure	negative control	$\Delta p = 35 \text{ bar}$	●	●	●	●	●	H5	
		positive control		●	●	●	●	●	H6	
	Override electric-proportional, integrated pilot valve	must always be combined with basic controller DG	positive control	de-energized in standby	$U = 24 \text{ V DC}$	○	○	○	○	○
negative control			energized in standby	$U = 24 \text{ V DC}$	○	○	○	○	○	T8

1) The basic controller (04) can be combined with at most two additional controllers (05, 06, 07).

The following variants are possible with two pressure controllers: DRDG, DRDP and DGDP.

2) Summation power-control of two power-controlled pumps

3) Summation power-control of one power-controlled and one fixed pump

Please refer to additional footnotes on page 3

4 **A15VSO, A15VLO series 10** | Axial piston variable pump
Ordering code

01	02	03	04	05	06	07	08	09	10	11	12	13	14	15	16	17	18	19	20	21		
A15V										/	10	M					1			0	-	

Drive shaft (for permissible input torque, see page 10)

		110	145	175	210	280		
16	Splined shaft DIN 5480	W45x2x21x9g	●	-	-	-	A1	
		W50x2x24x9g	-	●	●	●	A2	
		W60x2x28x9g	-	-	-	-	●	A4
	Parallel keyed shaft as per DIN 6885 ⁷⁾	∅ 45	●	-	-	-	-	B1
		∅ 50	-	●	●	●	-	B2
		∅ 60	-	-	-	-	●	B4

Service line ports

17	SAE flange port A, at side (45° right), SAE flange port S at bottom	1
----	---	----------

Rotary group versions

		110	145	175	210	280	
18	Noise-optimized for $n = 1500/1800$ rpm (only for A15VSO)	●	●	●	●	●	E
	High-speed version (only for A15VLO)	-	○	○	○	○	S

Through drives (for attachment options, see page 53)

		110	145	175	210	280						
19	Flange SAE J744	Hub for splined shaft										
	Diameter	Attachment ¹⁴⁾	Designation	Diameter	Designation							
	82-2 (A)	⊗	A3	5/8 in 9T 16/32DP ¹⁵⁾	S2	○	○	●	●	●	A3S2	
	101-2 (B)	⊗	B3	7/8 in 13T 16/32DP ¹⁵⁾	S4	○	○	●	●	●	B3S4	
				1 in 15T 16/32DP ¹⁵⁾	S5	○	○	●	●	●	B3S5	
	127-2 (C)	⊗	C3	1 1/4 in 14T 12/24DP ¹⁵⁾	S7	○	○	●	●	●	C3S7	
				1 1/2 in 17T 12/24DP ¹⁵⁾	S9	○	○	○	○	●	C3S9	
	152-4 (D)	⊗	D4	W45x2x21x9g ¹⁶⁾	A1	○	○	○	○	○	D4A1	
				W50x2x24x9g ¹⁶⁾	A2	○	○	○	○	○	D4A2	
	165-4 (E)	⊗	E4	W50x2x24x9g ¹⁶⁾	A2	●	●	●	●	●	E4A2	
				W60x2x28x9g ¹⁶⁾	A4	○	○	○	○	●	E4A4	
	Flange, ISO 3019-2 (metric)		Hub for splined shaft									
	Diameter	Attachment ¹⁴⁾	Designation	Diameter	Designation							
	80-2	⊗	K3	3/4 in 11T 16/32DP ¹⁵⁾	S3	○	○	○	○	○	K3S3	
		♂	K5	3/4 in 11T 16/32DP ¹⁵⁾	S3	○	○	○	●	○	K5S3	
	100-2	♂	L5	7/8 in 13T 16/32DP ¹⁵⁾	S4	○	○	○	○	○	L5S4	
	160-4	⊗	P4	1 1/4 in 14T 12/24DP ¹⁵⁾	S7	○	○	○	○	○	P4S7	
	180-4	⊗	R4	1 1/2 in 17T 12/24DP ¹⁵⁾	S9	○	○	○	○	●	R4S9	
				1 3/4 in 13T 8/16DP ¹⁵⁾	T1	○	○	○	○	○	R4T1	
125-4	⊗	M4	1 in 15T 16/32DP ¹⁵⁾	S5	○	○	○	○	○	M4S5		
			W32x2x14x9g ¹⁶⁾	Z7	○	○	○	○	○	M4Z7		
140-4	⊗	N4	W40x2x18x9g ¹⁶⁾	Z9	○	○	○	○	○	N4Z9		
Prepared for through drive, with pressure-resistant plugged cover							●	●	●	●	●	U000

Sensors

20	Without sensor	0
----	----------------	----------

Standard / special version

21	Standard version	0
	Special version	S

● = Available ○ = On request - = Not available

¹⁴⁾ Mounting drillings pattern viewed on through drive with control at top

¹⁵⁾ According to ANSI B92.1a

¹⁶⁾ According to DIN 5480

Hydraulic fluid

Before starting project planning, please refer to our data sheet 90220 (mineral oil) for detailed information regarding the selection of hydraulic fluid and application conditions. The A15VSO and A15VLO variable pumps are currently approved for operation with mineral oil. Please contact us about operation with environmentally acceptable or HF hydraulic fluids.

▼ Selection diagram

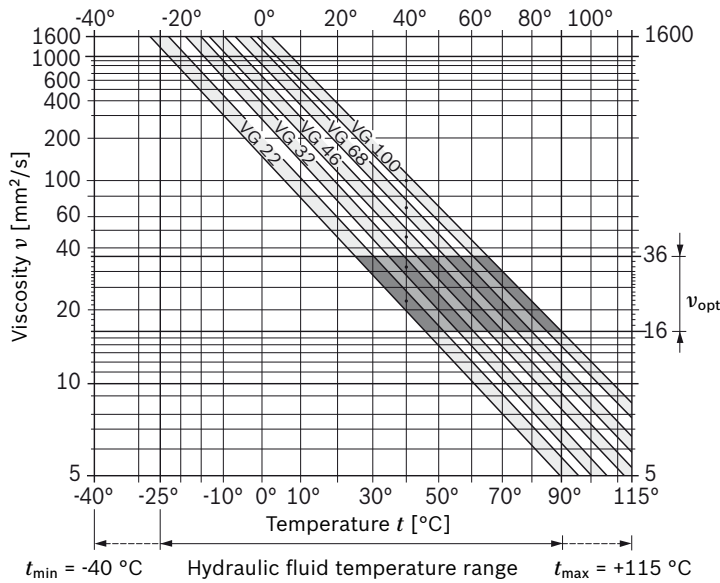

Details regarding the selection of hydraulic fluid

The correct selection of hydraulic fluid requires knowledge of the operating temperature in relation to the ambient temperature, in an open circuit the reservoir temperature. The hydraulic fluid should be selected so that the operating viscosity in the operating temperature range is within the optimum range (ν_{opt} see shaded area of the selection diagram). We recommended that the higher viscosity class be selected in each case.

Example: At an ambient temperature of X° C, an operating temperature of 60° C is set in the circuit. In the optimum operating viscosity range (ν_{opt} , shaded area), this corresponds to the viscosity classes VG 46 or VG 68; to be selected: VG 68.

Note

The case drain temperature, which is affected by pressure and rotational speed, can be higher than the reservoir temperature. At no point of the component may the temperature be higher than 115 °C. The temperature difference specified below is to be taken into account when determining the viscosity in the bearing.

If the above conditions cannot be maintained due to extreme operating parameters, please contact us.

Viscosity and temperature of hydraulic fluid

	Viscosity [mm ² /s]	Temperature	Comment
Transport and storage at ambient temperature		$T_{min} \geq -50$ °C $T_{opt} = +5$ °C to $+20$ °C	factory preservation: up to 12 months with standard, up to 24 months with long-term
(Cold) start-up ¹⁾	$\nu_{max} = 1600$	$T_{St} \geq -40$ °C	$t \leq 3$ min, low load ($20 \text{ bar} \leq p \leq 50 \text{ bar}$), $n \leq 1000$ rpm
Permissible temperature difference		$\Delta T \leq 25$ K	between axial piston unit and hydraulic fluid
Warm-up phase	$\nu < 1600$ to 400	$T = -40$ °C to -25 °C	at p_{nom} , $n \leq 0.5 \cdot n_{nom}$ and $t \leq 15$ min
Operating phase			
Temperature difference		$\Delta T =$ approx. 5 K	between hydraulic fluid in the bearing and at port T.
Maximum temperature		115 °C 110 °C	in the bearing measured at port T
Continuous operation	$\nu = 400$ to 10 $\nu_{opt} = 36$ to 16	$T = -25$ °C to $+90$ °C	measured at port T, no restriction within the permissible data
Short-term operation	$\nu_{min} = 10$ to 5	$T_{max} = +110$ °C	measured at port T, $t < 3$ min, $p < 0.3 \cdot p_{nom}$
FKM shaft seal ¹⁾		$T \leq +115$ °C	see page 6

1) At temperatures below -25 °C, an NBR shaft seal is required (permissible temperature range -40 °C to +90 °C)

Filtration of the hydraulic fluid

Finer filtration improves the cleanliness level of the hydraulic fluid, which increases the service life of the axial piston unit.

To ensure the functional reliability of the axial piston unit, a gravimetric analysis of the hydraulic fluid is necessary to determine the amount of solid contaminant and to determine the cleanliness level according to ISO 4406. A cleanliness level of at least 20/18/15 is to be maintained.

At very high hydraulic fluid temperatures (90 °C to maximum 115 °C), a cleanliness level of at least 19/17/14 according to ISO 4406 is necessary.

If the above levels cannot be achieved, please contact us.

Shaft seal

The FKM shaft seal may be used for case drain temperatures from -25 °C to +115 °C.

Note

For application cases below -25 °C, an NBR shaft seal is required (permissible temperature range -40 °C to +90 °C; ordering code digit 14, K). Please contact us.

Charge pump (impeller)

The charge pump is a circulating pump with which the A15VLO is filled and therefore can be operated at higher rotational speeds. This also simplifies cold starting at low temperatures and high viscosity of the hydraulic fluid. An external inlet pressure increase is therefore unnecessary in most cases. Charging the reservoir with compressed air is not permissible.

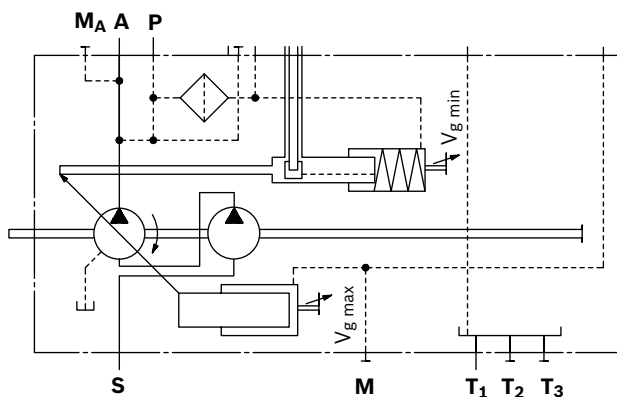

Operating pressure range

Pressure at service line port A		Definition
Nominal pressure p_{nom}	350 bar absolute	The nominal pressure corresponds to the maximum design pressure.
Maximum pressure p_{max}	420 bar absolute	The maximum pressure corresponds to the maximum operating pressure within the single operating period. The sum of the single operating periods must not exceed the total operating period.
Single operating period	10 s	
Total operating period	300 h	
Minimum pressure $p_{A abs}$ (high-pressure side)	15 bar	Minimum pressure on the high-pressure side (A) which is required in order to prevent damage to the axial piston unit. Please contact us about operation at low pressure.
Rate of pressure change $R_{A max}$	16000 bar/s	Maximum permissible rate of pressure build-up and reduction during a pressure change over the entire pressure range.
Pressure at suction port S (inlet)		
Version without charge pump		Minimum pressure at suction port S (inlet) which is required in order to avoid damage to the axial piston unit. The minimum pressure depends on the rotational speed and displacement of the axial piston unit.
Minimum pressure $p_{S min}$	≥ 0.8 bar absolute	
Maximum pressure $p_{S max}$	≤ 30 bar absolute	
Version with charge pump		
Minimum pressure $p_{S min}$	≥ 0.7 bar absolute	
Maximum pressure $p_{S max}$	≤ 2 bar absolute	
Case drain pressure at port T ₁ , T ₂ , T ₃		
Maximum pressure $p_{L max}$	4 bar absolute	Maximum 1.2 bar higher than inlet pressure at port S, but not higher than $p_{L max}$. A case drain line to the reservoir is required.

▼ Rate of pressure change $R_{A max}$

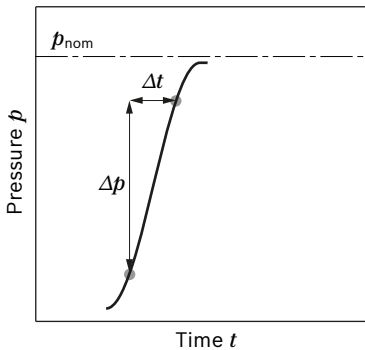

▼ Pressure definition

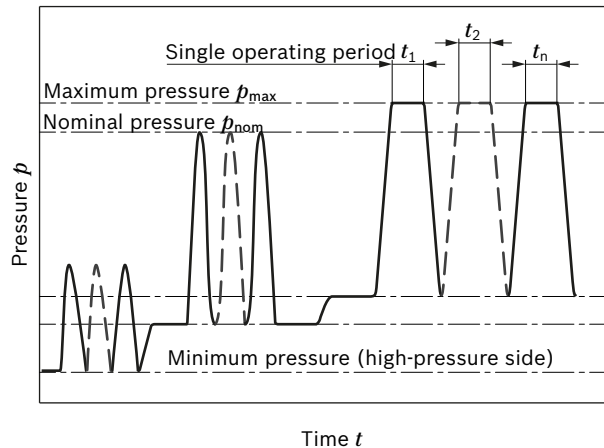

$$\text{Total operating period} = t_1 + t_2 + \dots + t_n$$

Note

Operating pressure range valid when using hydraulic fluids based on mineral oils. Values for other hydraulic fluids, please contact us.

Technical data

Without charge pump (A15VSO)

Size	NG		110	145	175	210	280		
Displacement geometric, per revolution	$V_{g \max}$		cm ³	110.0	145.0	175.0	210.0	280.0	
	$V_{g \min}$		cm ³	0 ¹⁾	0 ¹⁾	0 ¹⁾	0 ¹⁾	0 ¹⁾	
Maximum rotational speed ²⁾	at $V_{g \max}$ ³⁾		n_{nom}	rpm	2400	2300	2150	2100	1800
	at $V_g \leq V_{g \max}$ ⁴⁾		n_{max}	rpm	2800	2600	2500	2500	2300
Flow	at n_{nom} and $V_{g \max}$		q_v	l/min	264	334	376	441	504
Power	at n_{nom} , $V_{g \max}$ and $\Delta p = 350$ bar		P	kW	154	195	219	257	294
Torque	at $V_{g \max}$ and $\Delta p = 350$ bar ³⁾		T	Nm	613	808	975	1170	1560
Rotary stiffness drive shaft	W45x2x21x9g	A1	c	kNm/rad	242	–	–	–	–
	W50x2x24x9g	A2	c	kNm/rad	–	334	357	381	–
	W60x2x28x9g	A4	c	kNm/rad	–	–	–	–	645
	Ø45	B1	c	kNm/rad	236	–	–	–	–
	Ø50	B2	c	kNm/rad	–	337	349	372	–
	Ø60	B4	c	kNm/rad	–	–	–	–	620
Moment of inertia for rotary group			J_{GR}	kgm ²	0.022	0.035	0.045	0.06	0.097
Maximum angular acceleration ⁵⁾			α	rad/s ²	7465	6298	5609	5014	4200
Case volume			V	L	2.2	2.7	3.6	4	6.5
Weight (without through drive) approx.			m	kg	64	79	97	111	143

With charge pump (A15VLO)

Size	NG		145	175	210	280		
Displacement geometric, per revolution	$V_{g \max}$		cm ³	145.0	175.0	210.0	280.0	
	$V_{g \min}$		cm ³	0 ¹⁾	0 ¹⁾	0 ¹⁾	0 ¹⁾	
Maximum rotational speed ²⁾	at $V_{g \max}$ ³⁾		n_{nom}	rpm	2600	2500	2500	2300
	at $V_g \leq V_{g \max}$ ⁴⁾		n_{max}	rpm	2600	2500	2500	2300
Flow	at n_{nom} and $V_{g \max}$		q_v	l/min	377	438	525	644
Power	at n_{nom} , $V_{g \max}$ and $\Delta p = 350$ bar		P	kW	220	255	306	376
Torque	at $V_{g \max}$ and $\Delta p = 350$ bar ³⁾		T	Nm	808	975	1170	1560
Rotary stiffness drive shaft	W45x2x21x9g	A1	c	kNm/rad	–	–	–	–
	W50x2x24x9g	A2	c	kNm/rad	334	357	381	–
	W60x2x28x9g	A4	c	kNm/rad	–	–	–	645
	Ø45	B1	c	kNm/rad	–	–	–	–
	Ø50	B2	c	kNm/rad	337	349	372	–
	Ø60	B4	c	kNm/rad	–	–	–	620
Moment of inertia for rotary group			J_{GR}	kgm ²	0.035	0.047	0.063	0.097
Maximum angular acceleration ⁵⁾			α	rad/s ²	6298	5609	5014	4200
Case volume			V	L	2.9	3.6	3.7	5.6
Weight (without through drive) approx.			m	kg	92	110	125	148

1) Mooring function (swivel mode) possible up to –100% $V_{g \max}$.

2) The values are valid:

- for the optimum viscosity range from $\nu_{opt} = 36$ to 16 mm²/s
- with hydraulic fluid based on mineral oils

3) The values apply at absolute pressure $p_{abs} = 1$ bar at suction port **S**.

4) Maximum rotational speed (rotational speed limit) in the case of increasing the inlet pressure p_{abs} at suction port **S** and $V_g < V_{g \max}$, see diagram on page 9.

5) The data are valid for values between the minimum required and maximum permissible rotational speed. Valid for external excitation (e. g. diesel engine 2 to 8 times rotary frequency; cardan shaft twice the rotary frequency). The limit value applies for a single pump only. The load capacity of the connection parts must be considered.

▼ **Maximum permissible rotational speed (rotational speed limit)**
 ($p_{s\ abs}$ = inlet pressure)

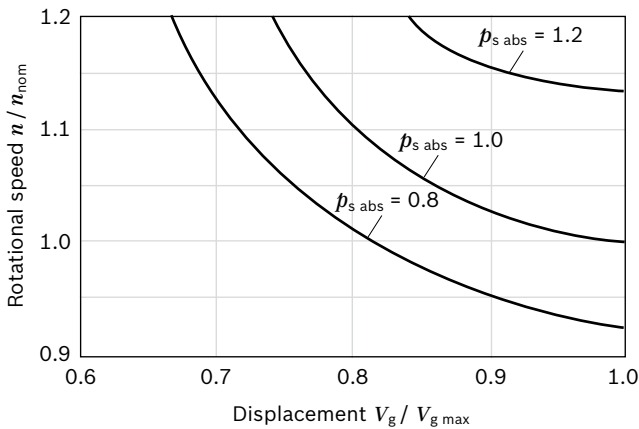

Determining the operating characteristics

Flow	$q_v = \frac{V_g \cdot n \cdot \eta_v}{1000}$	[L/min]
Torque	$T = \frac{V_g \cdot \Delta p}{20 \cdot \pi \cdot \eta_{mh}}$	[Nm]
Power	$P = \frac{2 \pi \cdot T \cdot n}{60000} = \frac{q_v \cdot \Delta p}{600 \cdot \eta_t}$	[kW]
Key		
V_g	=	Displacement per revolution [cm ³]
Δp	=	Differential pressure [bar]
n	=	Rotational speed [rpm]
η_v	=	Volumetric efficiency
η_{mh}	=	Mechanical-hydraulic efficiency
η_t	=	Total efficiency ($\eta_t = \eta_v \cdot \eta_{mh}$)

Permissible radial and axial forces of the drive shafts

Size	NG	110	110	145	145	175	175	210	210	280	280		
Drive shaft		Ø 45	W45	Ø 50	W50	Ø 50	W50	Ø 50	W50	Ø 60	W60		
Maximum radial force at distance a (from shaft collar)		$F_{q\ max}$	N	8000	8000	11000	11000	14000	14000	17000	17000	20000	23600
		a	mm	41	25	41	27.5	41	27	41	27	52.5	29
Maximum axial force		$+ F_{ax\ max}$	N	1200	1200	1350	1350	1400	1400	1450	1450	1800	1800
		$- F_{ax\ max}$	N	500	500	600	600	650	650	700	700	850	850

Note

- ▶ Theoretical values, without efficiency and tolerances; values rounded
- ▶ Operation above the maximum values or below the minimum values may result in a loss of function, a reduced service life or in the destruction of the axial piston unit. We recommend testing the loads by means of experiment or calculation / simulation and comparison with the permissible values.
- ▶ Special requirements apply in the case of belt drives. Please contact us.

Permissible input and through-drive torques

Size	NG		110	145	175	210	280	
Torque at $V_{g \max}$ and $\Delta p = 350 \text{ bar}^{1)}$		T_{\max}	Nm	610	808	975	1170	1560
Input torque at drive shaft, maximum ²⁾								
	A1	W45	$T_{E \max}$	Nm	2190	–	–	–
	A2	W50	$T_{E \max}$	Nm	–	3140	3140	3140
	A4	W60	$T_{E \max}$	Nm	–	–	–	5780
	B1	Ø 45	$T_{E \max}$	Nm	1050	–	–	–
	B2	Ø 50	$T_{E \max}$	Nm	–	1500	1500	1500
	B4	Ø 60	$T_{E \max}$	Nm	–	–	–	2800
Maximum through-drive torque		$T_{D \max}$	Nm	960	1110	1340	1915	2225

▼ **Torque distribution**

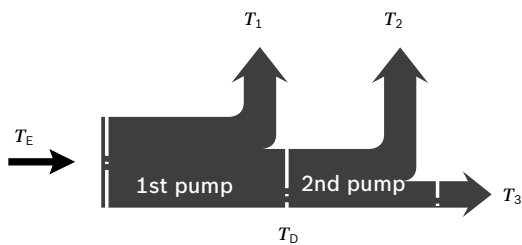

Torque at 1st pump	T_1
Torque at 2nd pump	T_2
Torque at 3rd pump	T_3
Input torque	$T_E = T_1 + T_2 + T_3$
	$T_E < T_{E \max}$
Through-drive torque	$T_D = T_2 + T_3$
	$T_D < T_{D \max}$

External control pressure supply
(ordering code digit 08 B and C)

Control systems with external control pressure supply need a flow appropriate to the adjustment time and size.

Size	Maximum flow [l/min]
110	10
145	13
175	14
210	17
280	22

1) Efficiency not considered

2) For drive shafts without radial force

Power controller

LR – Power controller, fixed setting

The power controller regulates the displacement of the pump depending on the operating pressure so that a given drive power is not exceeded at constant drive speed. The precise control with a hyperbolic control characteristic, provides an optimum utilization of available power. The operating pressure acts on a rocker via a measuring spool which moves with the control. An externally adjustable spring force counteracts this, it determines the power setting. The depressurized basic position is $V_{g \max}$. If the operating pressure exceeds the set spring force, the control valve will be actuated by the rocker and the pump will swivel back from the basic position $V_{g \max}$ toward $V_{g \min}$. Here, the leverage at the rocker may be shortened and the operating pressure may rise in the same relation as the displacement is reduced ($p_B \cdot V_g = \text{constant}$; p_B = operating pressure; V_g = displacement).

The hydraulic output power (characteristic LR) is influenced by the efficiency of the pump.

Setting range for beginning of control 50¹⁾ to 350 bar

When ordering, state in plain text:

- ▶ Drive power P [kW]
- ▶ Drive speed n [rpm]
- ▶ Maximum flow $q_{V \max}$ [l/min]

Please contact us if you need a power diagram.

▼ Characteristic LR

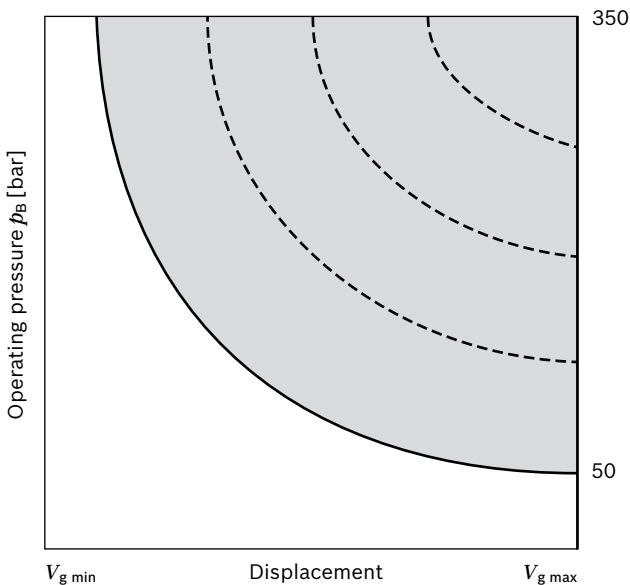

▼ Schematic LR

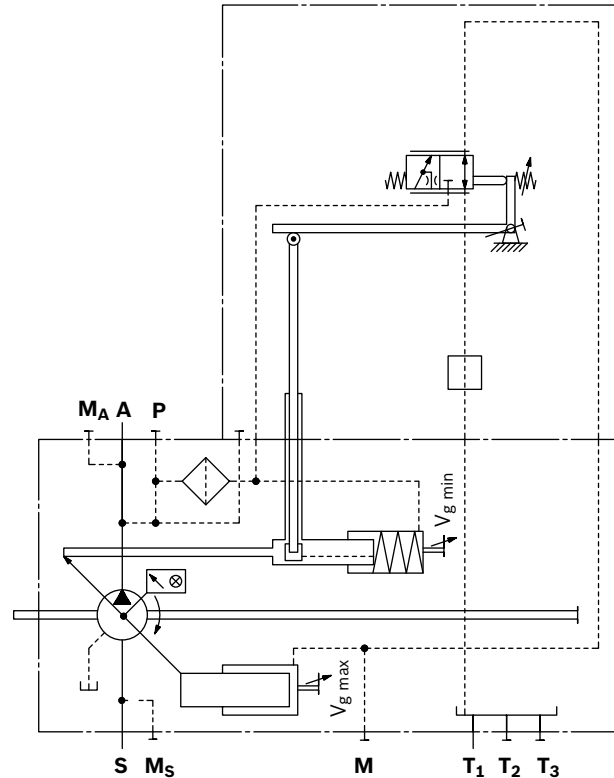

1) Smaller values on request

L4 – Power controller, electric-proportional override (negative control)

A control current acts against the mechanical power controller adjustment spring via a proportional solenoid. The mechanically adjusted basic power setting can be reduced by means of different control current settings. Increasing control current = reduced power.

The following amplifiers are recommended for industrial applications and are available for controlling the proportional solenoids:

- ▶ Analog amplifier VT-VSPA1-1 data sheet 30111
- ▶ Digital amplifier VT-VSPD-1 data sheet 30523

Further information can also be found on the internet at www.boschrexroth.com/industrial-hydraulics-catalog/

Technical data, solenoid	L4
Voltage	24 V (±20 %)
Control current	
Beginning of control	200 mA
End of control	600 mA
Limiting current	0.77 A
Nominal resistance (at 20 °C)	22.7 Ω
Dither frequency	100 Hz
Duty cycle	100 %
Type of protection see connector version page 55	

When ordering, state in plain text:

- ▶ Drive power P [kW] at beginning of control
- ▶ Drive speed n [rpm]
- ▶ Maximum flow $q_{V \max}$ [l/min]

▼ **Effect of power override with increasing current**

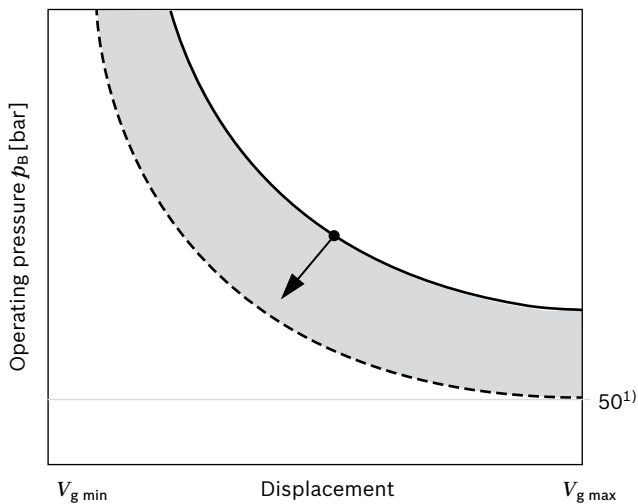

1) Smaller values on request

▼ **Schematic L4**

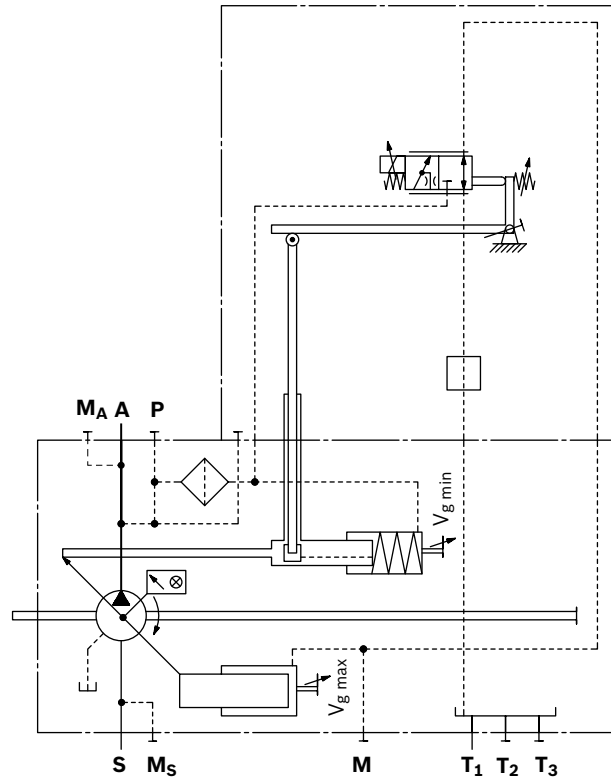

Change in beginning of control in bar when control current is changed from minimum to maximum.

Size	Δp Beginning of control in control range
	L4
	200 to 600 mA
110	215 bar
145	197 bar
175	230 bar
210	216 bar
280	196 bar

Note

For de-energized operating conditions: Beginning of control increase +50 bar

CR – Summation power-control of two power-controlled pumps, high-pressure-related override (with stop)

With two pumps of the same size working in different circuits, the CR controller limits the overall power. The CR works like the normal LR with a fixed maximum power setting along the power hyperbola. The high-pressure-related override reduces the power setpoint in dependence on the operating pressure of the other pump. That happens proportionally below the beginning of control and is blocked by a stop when the minimum power is reached. Here, the **CR** port of the one pump has to be connected to the **M_A** port of the other pump.

The maximum power of the first pump is reached when the second pump is working at idle when depressurized. When defining the maximum power, the idle power of the second pump has to be taken into account. The minimum power of each pump is reached when both pumps are working at high pressure. The minimum power usually equates to 50% of the total power.

Power that is released by the pressure control or other overrides remains unconsidered. Setting range for beginning of control 50¹⁾ to 300 bar

When ordering, please state separately for each pump:

- ▶ Maximum drive power P_{max} [kW]
- ▶ Minimum drive power P_{min} [kW]
- ▶ Drive speed n [rpm]
- ▶ Maximum flow q_{Vmax} [l/min]

▼ **Characteristic CR**

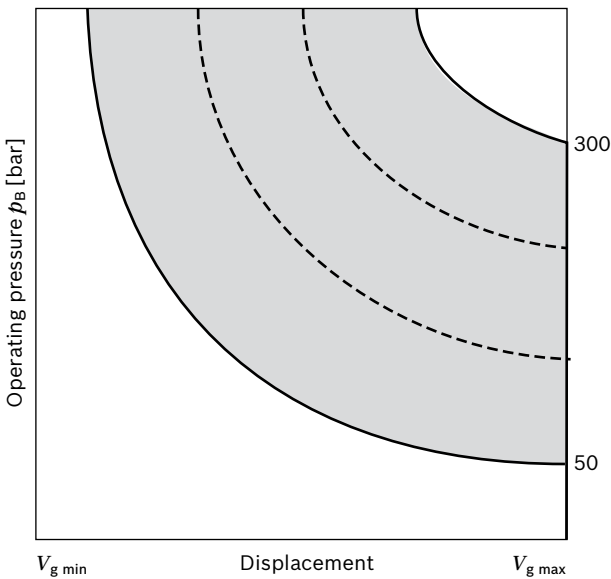

▼ **Schematic CR**

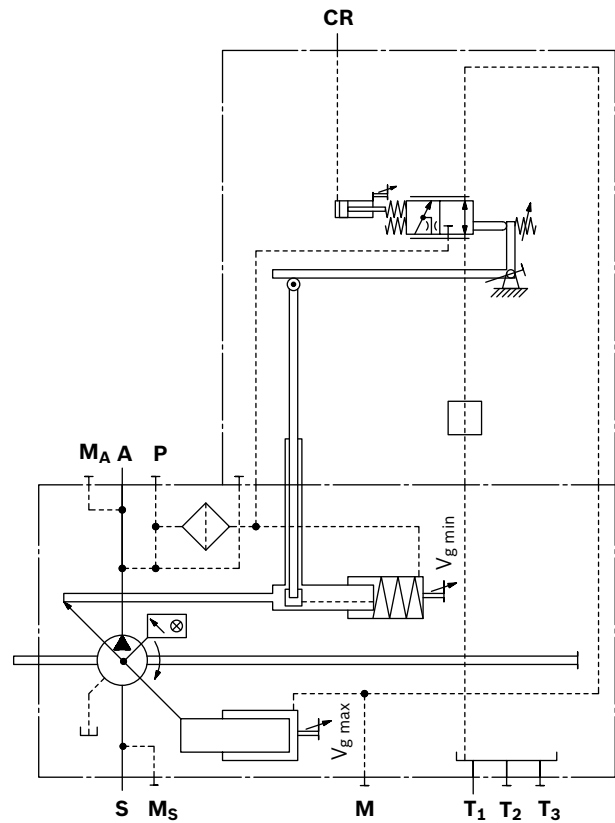

▼ **Effect of power override of a pump with increasing pressure in the 2nd pump**

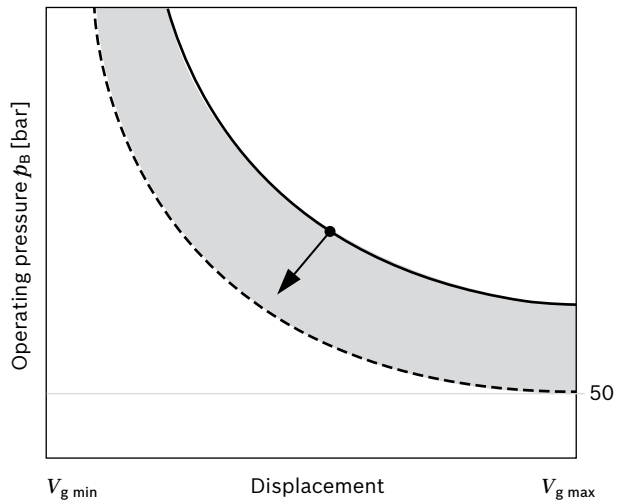

1) Smaller values on request

PR – Summation power-control of one power-controlled and one fixed pump

Together with the mounted fixed pump, the PR controller on an A15VSO or A15VLO effects a limitation of the overall power.

The PR works like the normal LR with a fixed maximum power setting along the power hyperbola. The high-pressure-dependent override reduces the power specification in proportion to the operating pressure of the fixed pump.

Here, port **PR** of the A15VSO or A15VLO must be connected to the operating pressure of the fixed pump.

The power of the controlled pump can then be reduced to zero in a borderline case.

The maximum power of the controlled pump is reached when the fixed pump works at idle when depressurized. When defining the maximum power, the idle power of the fixed pump has to be taken into account.

Power that is released by the pressure control or other overrides remains unconsidered.

Setting range for beginning of control 50¹⁾ to 350 bar

When ordering, state in plain text:

- ▶ Maximum drive power P_{max} [kW]
- ▶ Drive speed n [rpm]
- ▶ Maximum flow q_{Vmax} [l/min]
- ▶ Size of fixed pump

▼ Characteristic PR

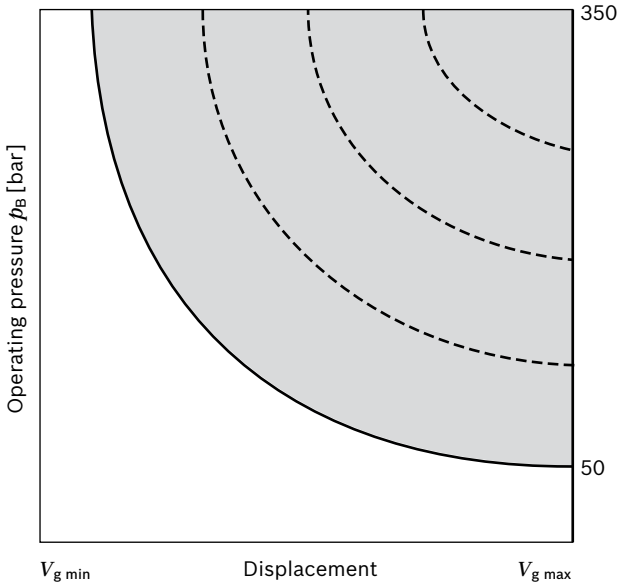

▼ Schematic PR

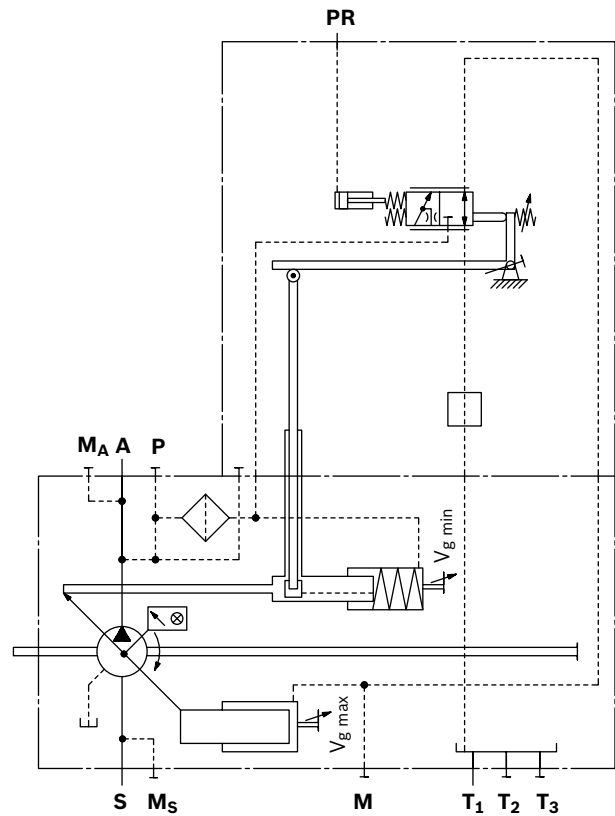

▼ Effect of power override of a pump with increasing pressure in the 2nd pump

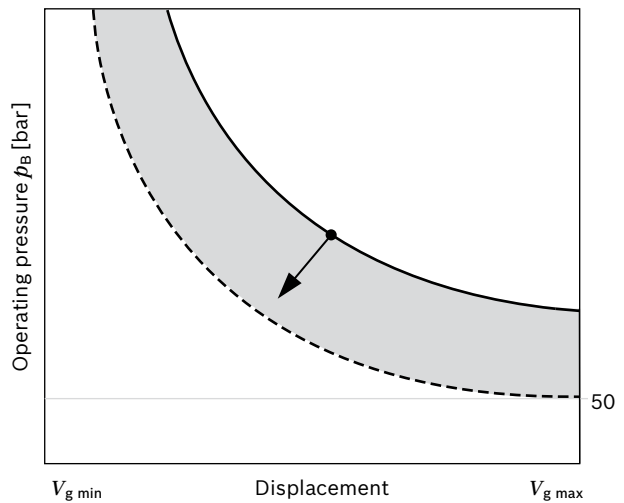

1) Smaller values on request

Stroke control

E2 – Stroke control, electric-proportional (positive control)

With the electric stroke control with proportional solenoid, the pump displacement is infinitely variable in proportion to the current by means of magnetic force.

Basic position without pilot signal is $V_{g \min}$. This includes the mechanically depressurized basic position $V_{g \min}$ (see ordering code digit 08).

With increasing control current the pump swivels to a higher displacement (from $V_{g \min}$ to $V_{g \max}$).

The necessary control fluid is taken from the operating pressure or the external control pressure applied to port **P**. In order for the pump to be moved from the basic position zero or at low operating pressure, port **P** must be supplied with external control pressure of at least 30 bar, maximum 50 bar.

Note

If there is no external control pressure applied to **P**, the version "Maximum swivel angle ($V_{g \max}$), without external control pressure supply" must be ordered (see ordering code digit 08, A).

The following amplifiers are recommended for industrial applications and are available for controlling the proportional solenoids:

- ▶ Analog amplifier VT-VSPA1-1 data sheet 30111
- ▶ Analog amplifier module VT-MSPA1 data sheet 30224
- ▶ Digital amplifier VT-VSPD-1 data sheet 30523

Further information can also be found on the internet at www.boschrexroth.com/industrial-hydraulics-catalog/

Technical data, solenoid	E2
Voltage	24 V ($\pm 20\%$)
Control current	
Beginning of control at $V_{g \min}$	200 mA
End of control at $V_{g \max}$	600 mA ¹⁾
Limiting current	0.77 A
Nominal resistance (at 20 °C)	22.7 Ω
Dither frequency	100 Hz
Duty cycle	100 %
Type of protection see connector version page 55	

▼ Characteristic E2

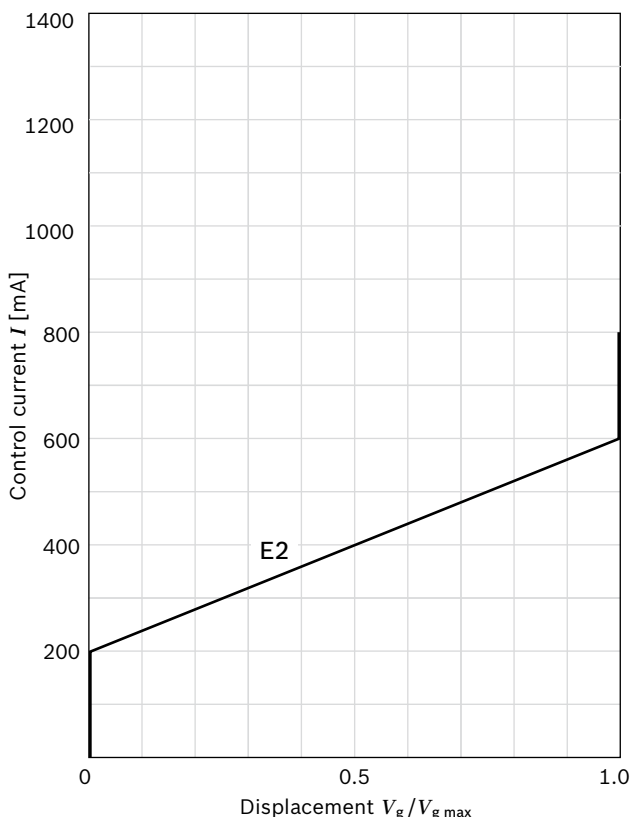

¹⁾ Because of the control hysteresis, a control current of up to 650 mA may be required for the $V_{g \max}$ position.

▼ **Schematic E2**

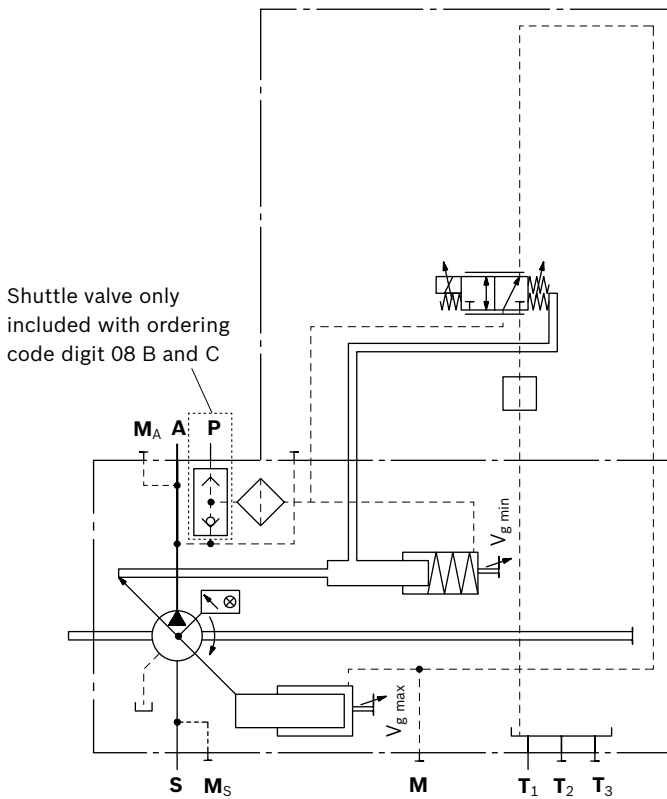

Note!

The spring feedback in the controller is not a safety device.

The controller can stick in an undefined position by internal contamination (contaminated hydraulic fluid, abrasion or residual contamination from system components). As a result, the flow of the axial piston unit will no longer respond correctly to the operator's commands.

Check whether the application on your machine requires additional safety measures, in order to bring the driven consumer into a safe position (immediate stop). If necessary, make sure that these are properly implemented.

E6 – Stroke control, electric, proportional (positive control)

With the electric two-point stroke control with switching solenoid, the displacement of the pump is adjusted between $V_{g \min}$ and $V_{g \max}$.

Basic position without current is $V_{g \min}$. This includes the mechanically depressurized basic position $V_{g \min}$ (see ordering code digit 08).

When the solenoid is energized, the pump swivels from $V_{g \min}$ to $V_{g \max}$.

The necessary control power is taken from the operating pressure or the external control pressure applied to port **P**. If the pump is to be adjusted from the basic position $V_{g \min}$ or from a low operating pressure, port **P** must be supplied with an external control pressure of at least 30 bar, maximum 50 bar.

Note

If there is no external control pressure applied to **P**, the version "Maximum swivel angle ($V_{g \max}$), without external control pressure supply" must be ordered (see ordering code digit 08, A).

Technical data, solenoid	E6
Voltage	24 V
Nominal resistance (at 20 °C)	21.7 Ω
Nominal power	26.5 W
Test current	0.67 A
Duty cycle	100 %
Type of protection see connector version page 55	

▼ Schematic E6

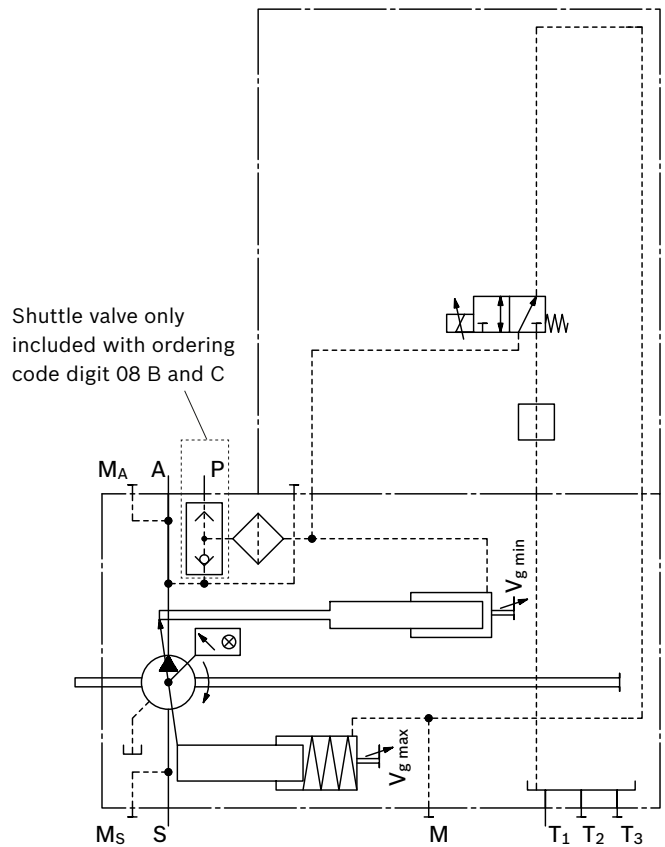

Note

The spring feedback in the controller is not a safety device. The controller can stick in an undefined position by internal contamination (contaminated hydraulic fluid, abrasion or residual contamination from system components). As a result, the flow of the axial piston unit will no longer respond correctly to the operator's commands. Check whether the application on your machine requires additional safety measures, in order to bring the driven consumer into a controlled and safe position (e. g. immediate stop). If necessary, make sure that these are properly implemented.

H3 – Stroke control, hydraulic-proportional, pilot pressure (negative control)

With pilot-pressure-related control, the pump displacement is adjusted in proportion to the pilot pressure applied at port **H3**.

Basic position without pilot signal is $V_{g \max}$. This includes the mechanically depressurized basic position $V_{g \max}$ (see ordering code digit 08, B).

- ▶ Maximum permissible pilot pressure $p_{St \max} = 100$ bar
- ▶ Adjustment from $V_{g \max}$ to $V_{g \min}$
With increasing pilot pressure, the pump swivels to a smaller displacement.
- ▶ Setting range for beginning of control (at $V_{g \max}$)
5 to 10 bar, standard is 10 bar.

State beginning of control in clear text in the order.

The necessary control fluid is taken from the operating pressure or the external control pressure applied to port **P**. If the pump is to be adjusted from the basic position $V_{g \min}$ or from a low operating pressure, port **P** must be supplied with an external control pressure of at least 30 bar, maximum 50 bar.

Note

If there is no external control pressure applied to **P**, the version "Maximum swivel angle ($V_{g \max}$), without external control pressure supply" must be ordered (see ordering code digit 08, A).

▼ **Characteristic H3 (negative)**

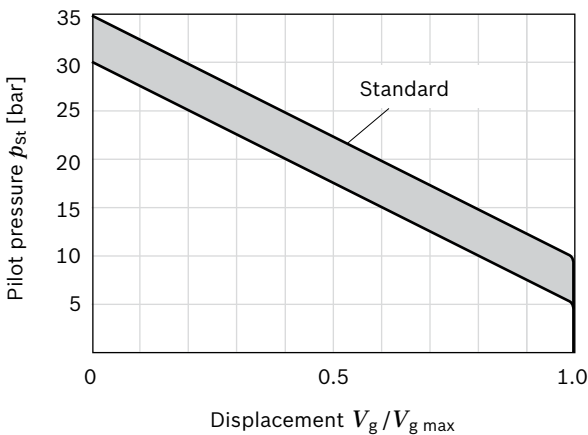

Increase in pilot pressure $V_{g \max}$ to $V_{g \min}$: $\Delta p = 25$ bar

When ordering, state in plain text:

- ▶ Beginning of control [bar] at $V_{g \max}$

▼ **Schematic H3**

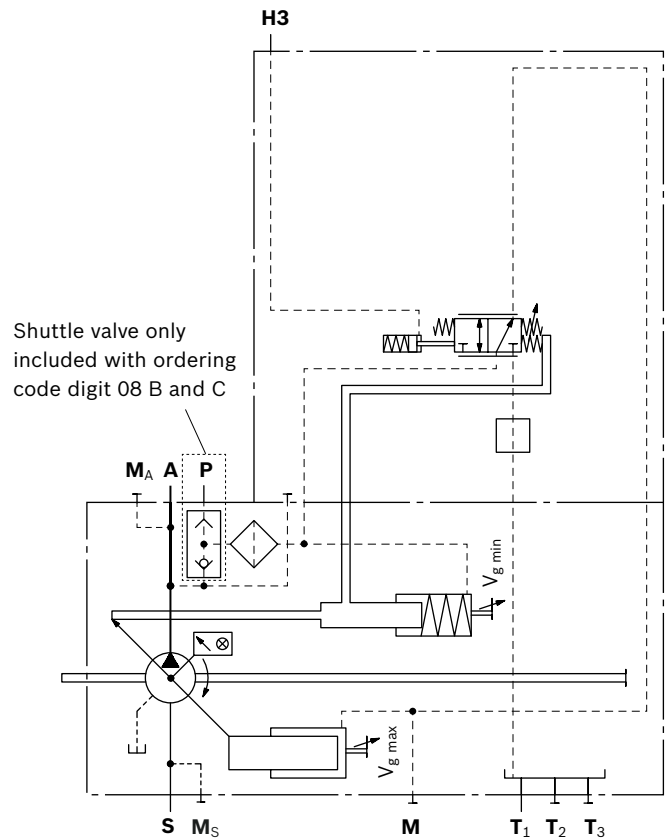

Note!

The spring feedback in the controller is not a safety device.

The controller can stick in an undefined position by internal contamination (contaminated hydraulic fluid, abrasion or residual contamination from system components). As a result, the flow of the axial piston unit will no longer respond correctly to the operator's commands. Check whether the application on your machine requires additional safety measures, in order to bring the driven consumer into a safe position (immediate stop). If necessary, make sure that these are properly implemented.

H4 – Stroke control, hydraulic-proportional, pilot pressure (positive control)

With pilot-pressure-related control, the pump displacement is adjusted in proportion to the pilot pressure applied at port **H4**.

Basic position is $V_{g \min}$. This includes the mechanically depressurized basic position $V_{g \min}$ (see ordering code digit 08, C).

- ▶ Maximum permissible pilot pressure $p_{St \max} = 100$ bar
- ▶ Adjustment from $V_{g \min}$ to $V_{g \max}$
With increasing pilot pressure, the pump swivels to a larger displacement.
- ▶ Setting range for beginning of control (at $V_{g \min}$)
5 to 10 bar, standard is 10 bar.
- ▶ State beginning of control in clear text in the order.

The necessary control fluid is taken from the operating pressure or the external control pressure applied to port **P**. If the pump is to be adjusted from the basic position $V_{g \min}$ or from a low operating pressure, port **P** must be supplied with an external control pressure of at least 30 bar, maximum 50 bar.

Note

If there is no external control pressure applied to **P** the version "Maximum swivel angle ($V_{g \max}$), without external control pressure supply" must be ordered (see ordering code digit 08, A).

▼ **Characteristic H4 (positive)**

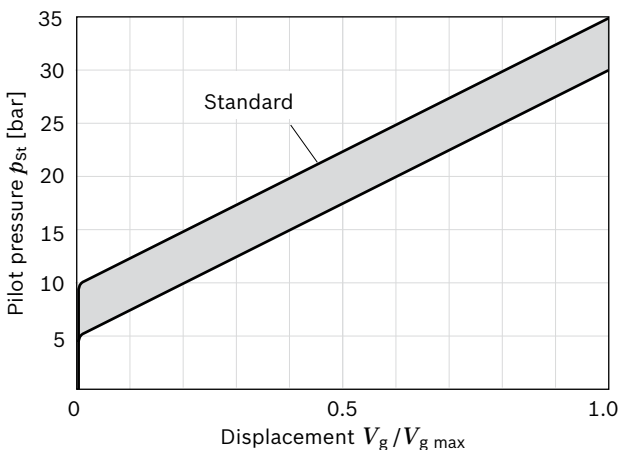

Increase in pilot pressure $V_{g \min}$ to $V_{g \max}$: $\Delta p = 25$ bar
When ordering, state in plain text:

- ▶ Beginning of control [bar] at $V_{g \min}$

▼ **Schematic H4**

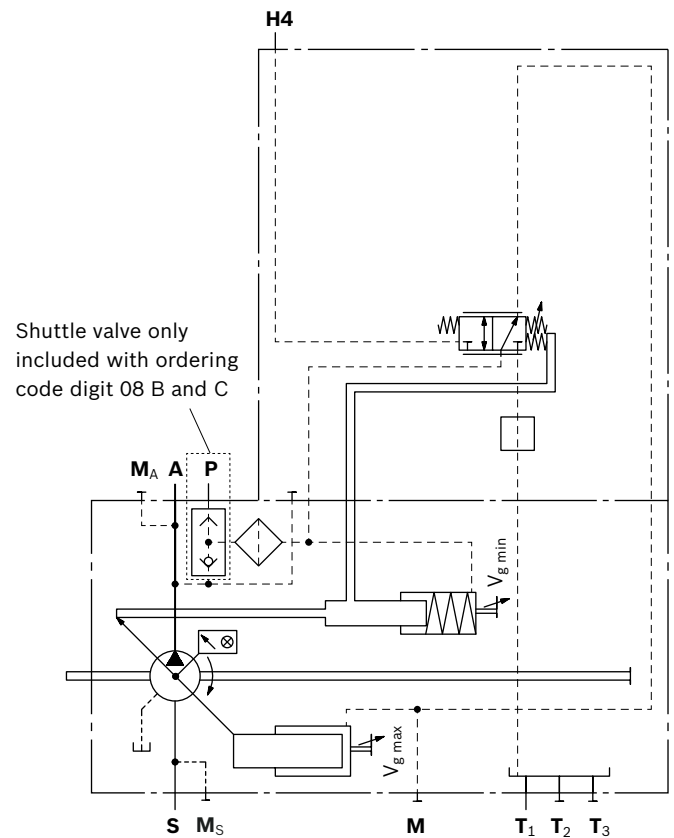

Note!

The spring feedback in the controller is not a safety device.
The controller can stick in an undefined position by internal contamination (contaminated hydraulic fluid, abrasion or residual contamination from system components). As a result, the flow of the axial piston unit will no longer respond correctly to the operator's commands.
Check whether the application on your machine requires additional safety measures, in order to bring the driven consumer into a safe position (immediate stop). If necessary, make sure that these are properly implemented.

H5 – Stroke control, hydraulic-proportional, pilot pressure (negative control)

With pilot-pressure-related control, the pump displacement is adjusted in proportion to the pilot pressure applied at port **H5**.

Basic position without pilot signal is $V_{g \max}$, this includes the mechanically depressurized basic position $V_{g \max}$ (see ordering code digit 08).

- ▶ Maximum permissible pilot pressure $p_{St \max} = 100$ bar
- ▶ Adjustment from $V_{g \max}$ to $V_{g \min}$
With increasing pilot pressure, the pump swivels to a smaller displacement.
- ▶ Beginning of control (at $V_{g \max}$) 10 bar

The necessary control fluid is taken from the operating pressure or the external control pressure applied to port **P**. If the pump is to be adjusted from the basic position $V_{g \min}$ or from a low operating pressure, port **P** must be supplied with an external control pressure of at least 30 bar, maximum 50 bar.

Note

If no external control pressure is connected to **P**, the version "Maximum swivel angle ($V_{g \max}$), without external control pressure supply" must be ordered (see ordering code digit 08, A).

▼ **Schematic H5**

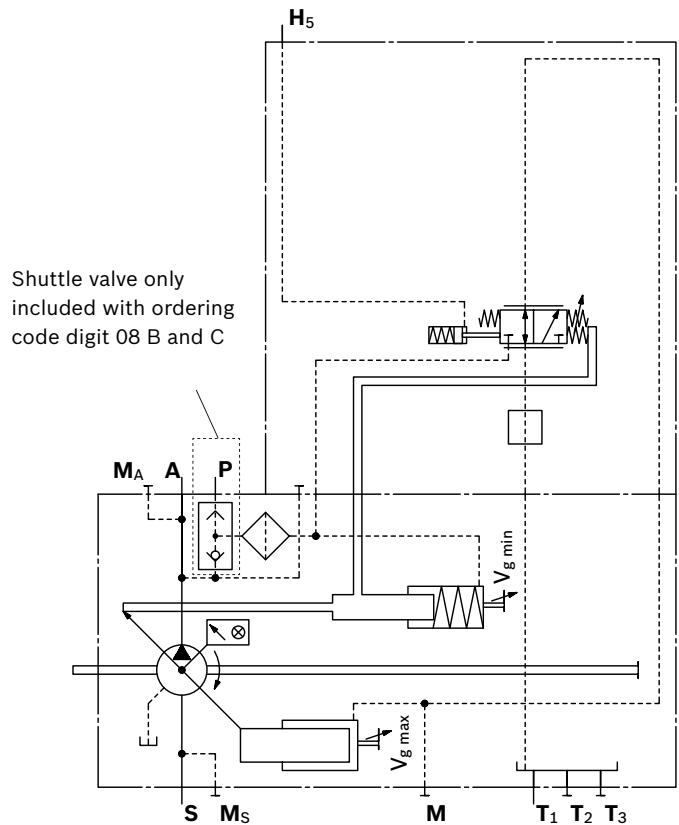

▼ **Characteristic H5 (negative)**

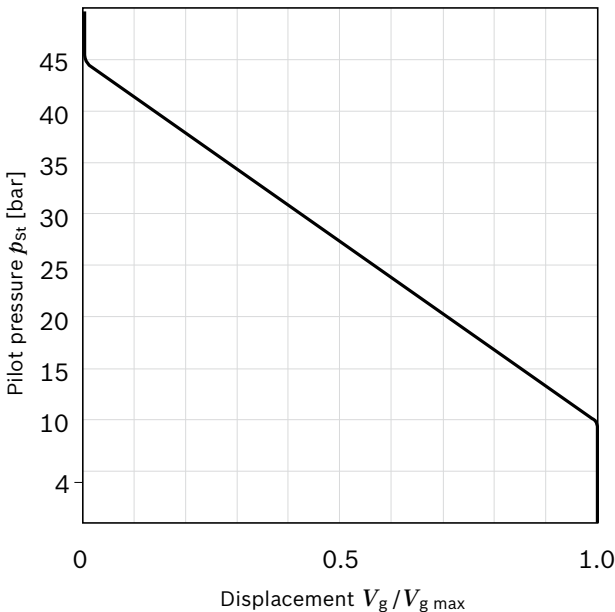

Increase in pilot pressure $V_{g \max}$ to $V_{g \min}$: $\Delta p = 35$ bar

Note!

The spring feedback in the controller is not a safety device. The controller can stick in an undefined position by internal contamination (contaminated hydraulic fluid, abrasion or residual contamination from system components). As a result, the flow of the axial piston unit will no longer respond correctly to the operator's commands. Check whether the application on your machine requires additional safety measures, in order to bring the driven consumer into a safe position (immediate stop). If necessary, make sure that these are properly implemented.

H6 – Stroke control, hydraulic-proportional, pilot pressure (positive control)

With pilot-pressure-related control, the pump displacement is adjusted in proportion to the pilot pressure applied at port **H6**.

Basic position without pilot signal is $V_{g \min}$, this includes the mechanically depressurized basic position $V_{g \min}$ (see ordering code digit 08).

- ▶ Maximum permissible pilot pressure $p_{St \max} = 100$ bar
- ▶ Adjustment from $V_{g \min}$ to $V_{g \max}$
With increasing pilot pressure, the pump swivels to a smaller displacement.
- ▶ Start of control (at $V_{g \min}$) 10 bar.

The necessary control fluid is taken from the operating pressure or the external control pressure applied to port **P**. If the pump is to be adjusted from the basic position $V_{g \min}$ or from a low operating pressure, port **P** must be supplied with an external control pressure of at least 30 bar, maximum 50 bar.

Note

If no external control pressure is connected to **P**, the version "Maximum swivel angle ($V_{g \max}$), without external control pressure supply" must be ordered (see ordering code digit 08, A).

▼ **Characteristic H6 (positive)**

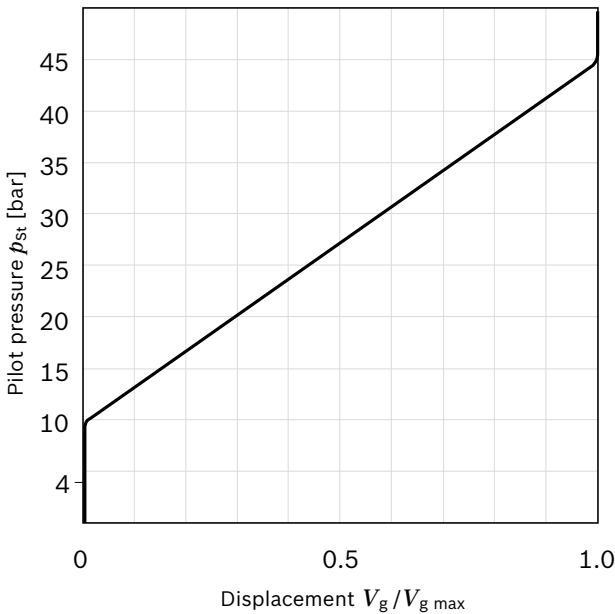

Increase in pilot pressure $V_{g \min}$ to $V_{g \max}$: $\Delta p = 35$ bar

▼ **Schematic H6**

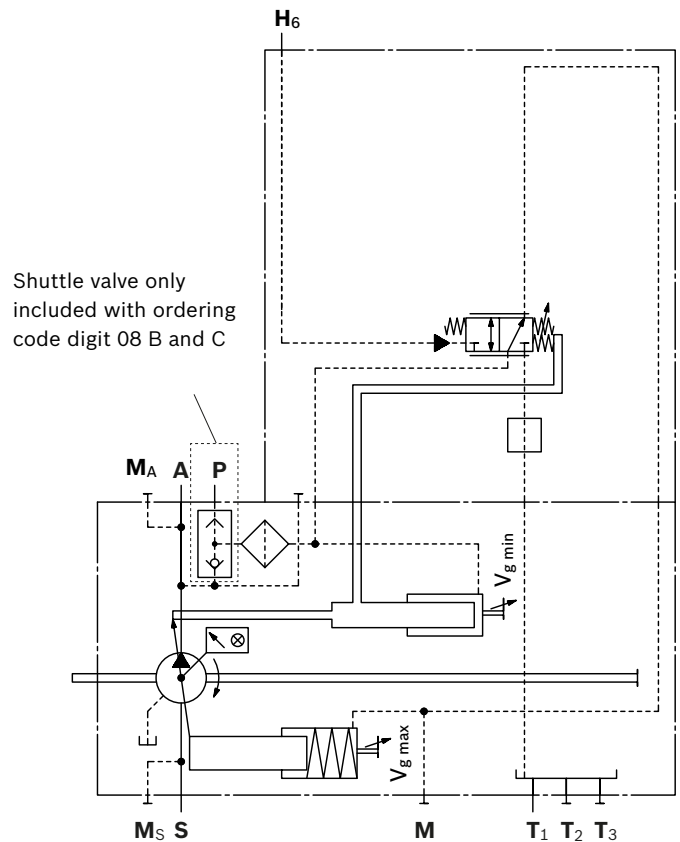

Shuttle valve only included with ordering code digit 08 B and C

Note!

The spring feedback in the controller is not a safety device. The controller can stick in an undefined position by internal contamination (contaminated hydraulic fluid, abrasion or residual contamination from system components). As a result, the flow of the axial piston unit will no longer respond correctly to the operator's commands. Check whether the application on your machine requires additional safety measures, in order to bring the driven consumer into a safe position (immediate stop). If necessary, make sure that these are properly implemented.

Pressure controller

DR – Pressure controller with one-side swiveling, fixed setting

The pressure controller limits the maximum pressure at the pump outlet within the control range of the variable pump. The variable pump only delivers as much hydraulic fluid as is required by the consumers. If the operating pressure exceeds the setpoint value set at the pressure valve, the pump will regulate to a smaller displacement to reduce the control differential.

- ▶ Basic position in depressurized state: $V_{g \max}$
- ▶ Setting range for pressure control: 50 to 350 bar.
Standard is 350 bar.

▼ Characteristic DR

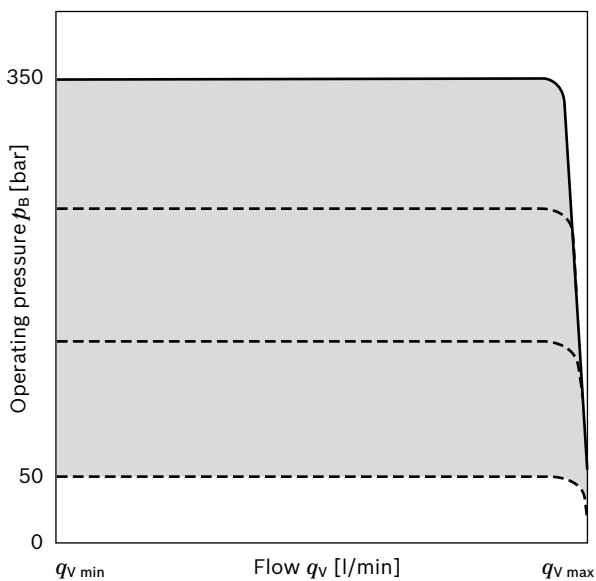

Hydraulic $V_{g \min}$ stop

The hydraulic $V_{g \min}$ stop opens the valve outlet to the case drain chamber when a minimum position is reached, damping the controller and reducing overshoot. This can create a connection from high pressure or external control pressure via the controller and the hydraulic $V_{g \min}$ stop to the case drain chamber.

When ordering, state in plain text:

- ▶ Pressure setting p [bar] at pressure controller DR

▼ Schematic DR

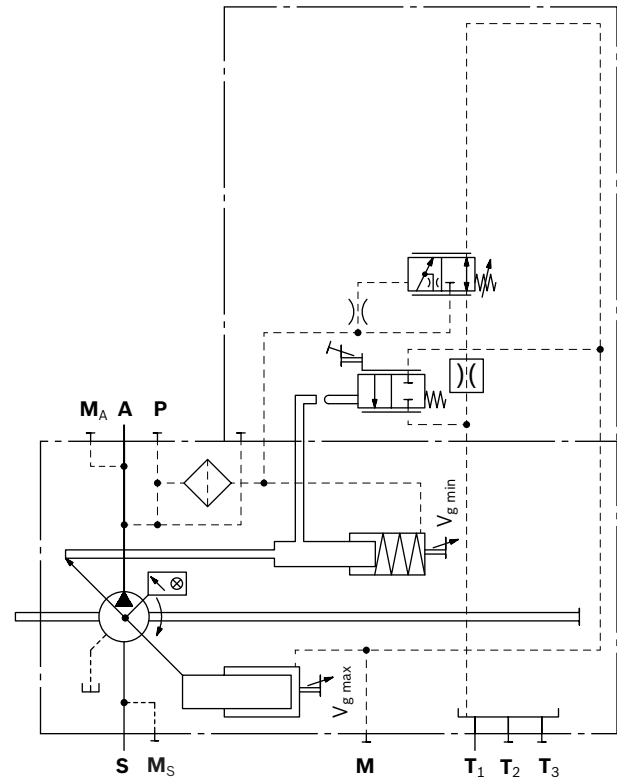

DRS0 – Pressure controller with load sensing

The load sensing controller works as a load-pressure controlled flow controller and adjusts the displacement of the pump to the volume required by the consumer.

The flow of the pump is then dependent on the cross section of the external measuring orifice (1), which is located between the pump and the consumer. Below the setting of the pressure controller and within the control range of the pump, the flow is not dependent on the load pressure.

As a rule, the measuring orifice is a separately located load sensing directional valve (control block). The position of the directional valve piston determines the opening cross section of the measuring orifice and thus the flow of the pump.

The load sensing controller compares pressure before and after the measuring orifice and keeps the pressure drop (differential pressure Δp) across the orifice – and therefore the flow – constant.

If the differential pressure Δp at the measuring orifice rises, the pump is swiveled back (toward $V_{g\ min}$). If the differential pressure Δp drops, the pump is swiveled out (toward $V_{g\ max}$) until equilibrium at the measuring orifice is restored.

$$\Delta p_{\text{Measuring orifice}} = p_{\text{Pump}} - p_{\text{Consumer}}$$

- ▶ Setting range for Δp 14 to 30 bar (please state in plain text)
- ▶ Standard setting 14 bar

The stand-by pressure in zero-stroke operation (measuring orifice closed) is slightly higher than the Δp setting.

▼ **Characteristic DRS0**

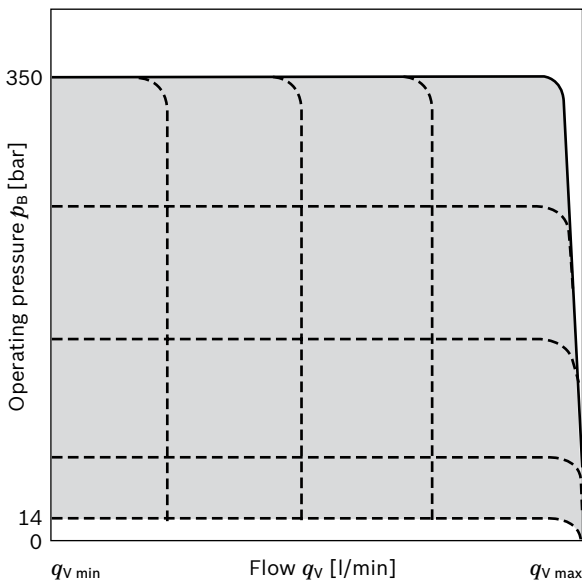

Hydraulic $V_{g\ min}$ stop

The hydraulic $V_{g\ min}$ stop opens the valve outlet to the case drain chamber when a minimum position is reached, damping the controller and reducing overshoot. This can create a connection from high pressure or external control pressure via the controller and the hydraulic $V_{g\ min}$ stop to the case drain chamber.

When ordering, state in plain text:

- ▶ Pressure setting p [bar] at pressure controller DR
- ▶ Differential pressure Δp [bar] at load sensing controller S0

▼ **Schematic DRS0**

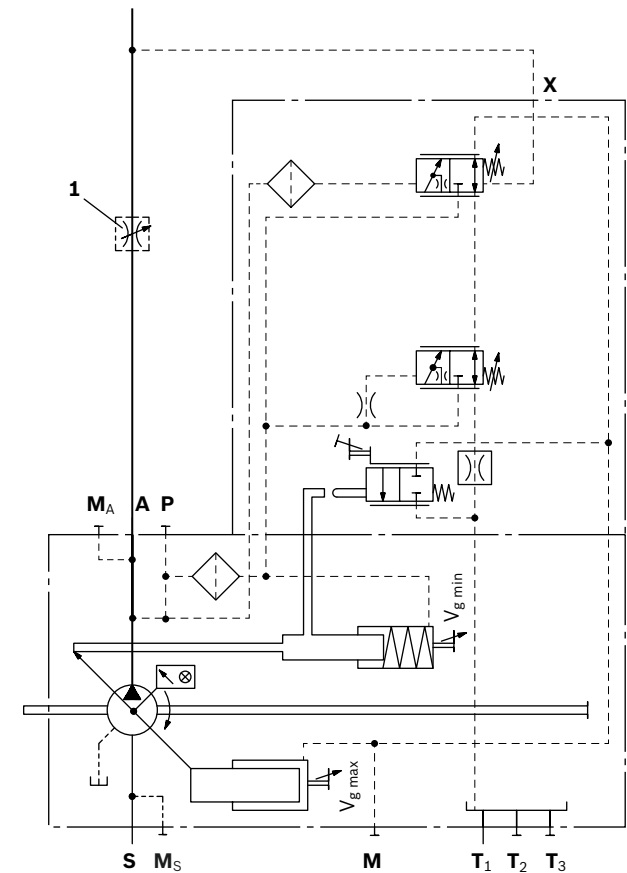

1 The measuring orifice (control block) is not included in the scope of supply.

DG – Pressure controller with one-side swiveling, hydraulically remote controlled (positive control)

The remote controlled pressure controller has a fixed-setting Δp value. A separately connected pressure-relief valve at port **X** (1) enables the pressure control to be remotely controlled.

- ▶ Setting range Δp 14 to 25 bar
- ▶ Recommended value 20 bar (standard)
- ▶ Control volume at **X**: approx. 1.6 l/min (static) at Δp 20 bar

In addition a separately configured 2/2 directional valve (2) can be operated to start the pump with low operating pressure (standby pressure).

Both functions can be used individually or in combination (see schematic).

The external valves are not included in the scope of supply.

As a separate pressure-relief valve (1) we recommend:

- ▶ For DBD.6, see data sheet 25402

Hydraulic $V_{g\ min}$ stop

The hydraulic $V_{g\ min}$ stop opens the valve outlet to the case drain chamber when a minimum position is reached, damping the controller and reducing overshoot. This can create a connection from high pressure or external control pressure via the controller and the hydraulic $V_{g\ min}$ stop to the case drain chamber.

- ▶ Operating pressure p in bar (test pressure for DG)
- ▶ Differential pressure Δp in bar
- ▶ Drive speed n in rpm
- ▶ Maximum flow $qV_{\ max}$ in l/min

Note for setting remote controlled pressure control

The setting value for the external pressure relief valve plus the differential pressure value at the pressure control valve determines the level of pressure control.

Example:

- ▶ External pressure relief valve 330 bar
- ▶ Differential pressure at pressure control valve 20 bar
- ▶ Pressure control at 330 + 20 = 350 bar

▼ **Characteristic DG**

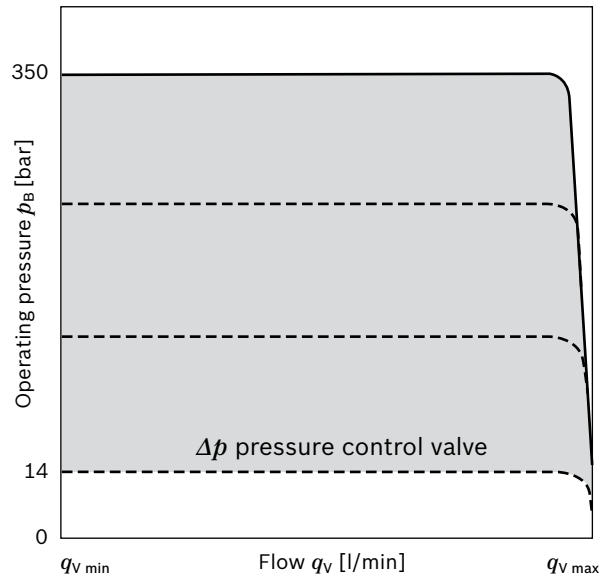

For function and description of pressure control DR, see page 22

▼ **Schematic DG**

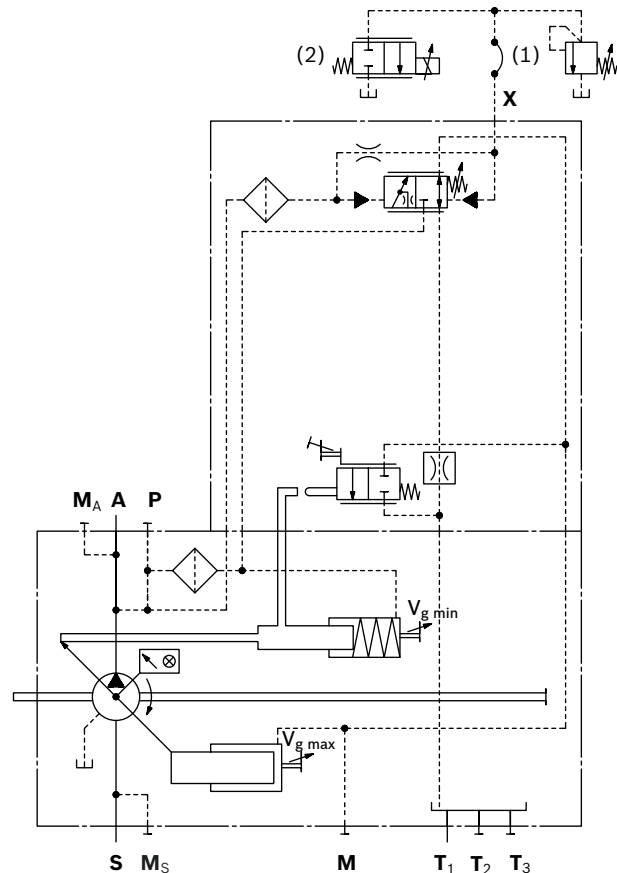

- 1 Pressure-relief valve (not included in the scope of supply)
- 2 2/2 directional valve (not included in the scope of supply)

DP – Pressure controller with one-side swiveling for parallel operation (positive control)

The pressure controller DP is suitable for pressure control of several A15VSO or A15VLO axial piston pumps in parallel operation pumping into a common pressure line.

The pressure control has a pressure increase of approx. 7 bar from $q_{v \max}$ to $q_{v \min}$. The pump regulates therefore to a pressure dependent swivel angle. This means a parallel or synchronous control behavior of several pumps.

The DP controller has a fixed Δp value which is overridden, depending on the swivel angle. Reference operating point is zero stroke.

Setting value Δp at zero stroke 27 bar.

With the externally installed pressure-relief valve (1) the nominal pressure setting of all pumps connected to the system is adjusted to the same value.

Setting range from 50 to 350 bar.

Control current for DP: approx. 1.9 l/min (static) at Δp 27 bar.

Each pump can be individually unloaded from the system by a separately installed 2/2-way directional valve (2) and set to a standby position.

The check valve in the service line (port **A**) is generally to be provided by the customer. The check valve in the control line (port **DP**) is included in the scope of supply.

The external valves are not included in the scope of supply. As a separate pressure-relief valve (1) we recommend: DBD.6 (manual operation) see data sheet 25402

Hydraulic $V_{g \min}$ stop

The hydraulic $V_{g \min}$ stop opens the valve outlet to the case drain chamber when a minimum position is reached, damping the controller and reducing overshoot. This can create a connection from high pressure or external control pressure via the controller and the hydraulic $V_{g \min}$ stop to the case drain chamber.

Characteristic DP

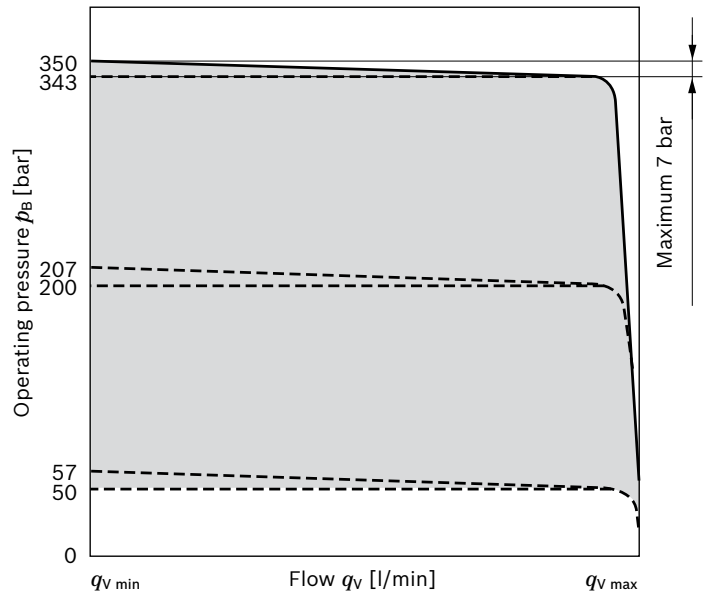

▼ Schematic DP

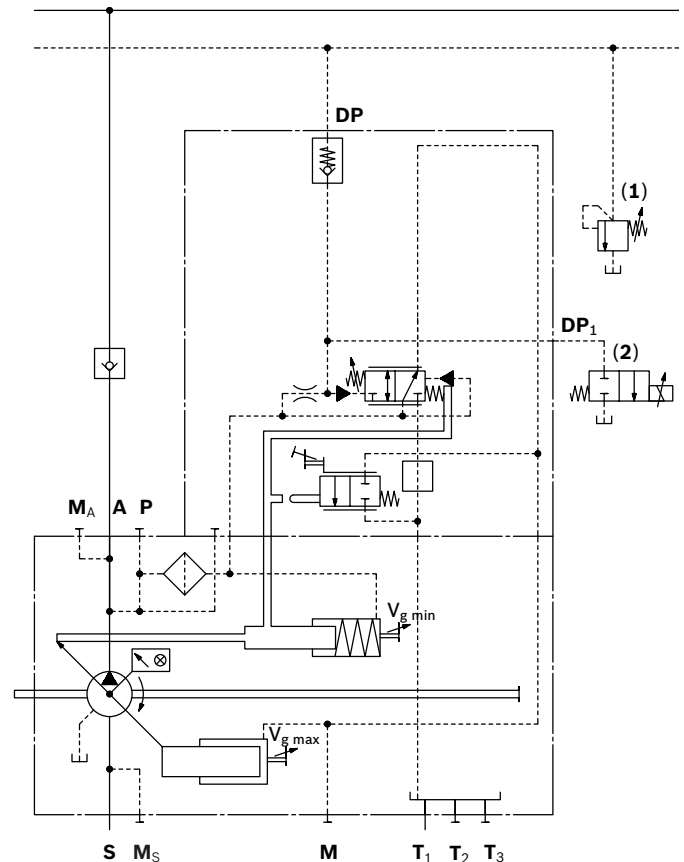

- 1 Pressure-relief valve (not included in the scope of supply)
- 2 2/2 directional valve (not included in the scope of supply)

Dimensions size 110

LRDRS0 – Power controller with pressure controller, load sensing and with electric swivel angle sensor

Clockwise rotation

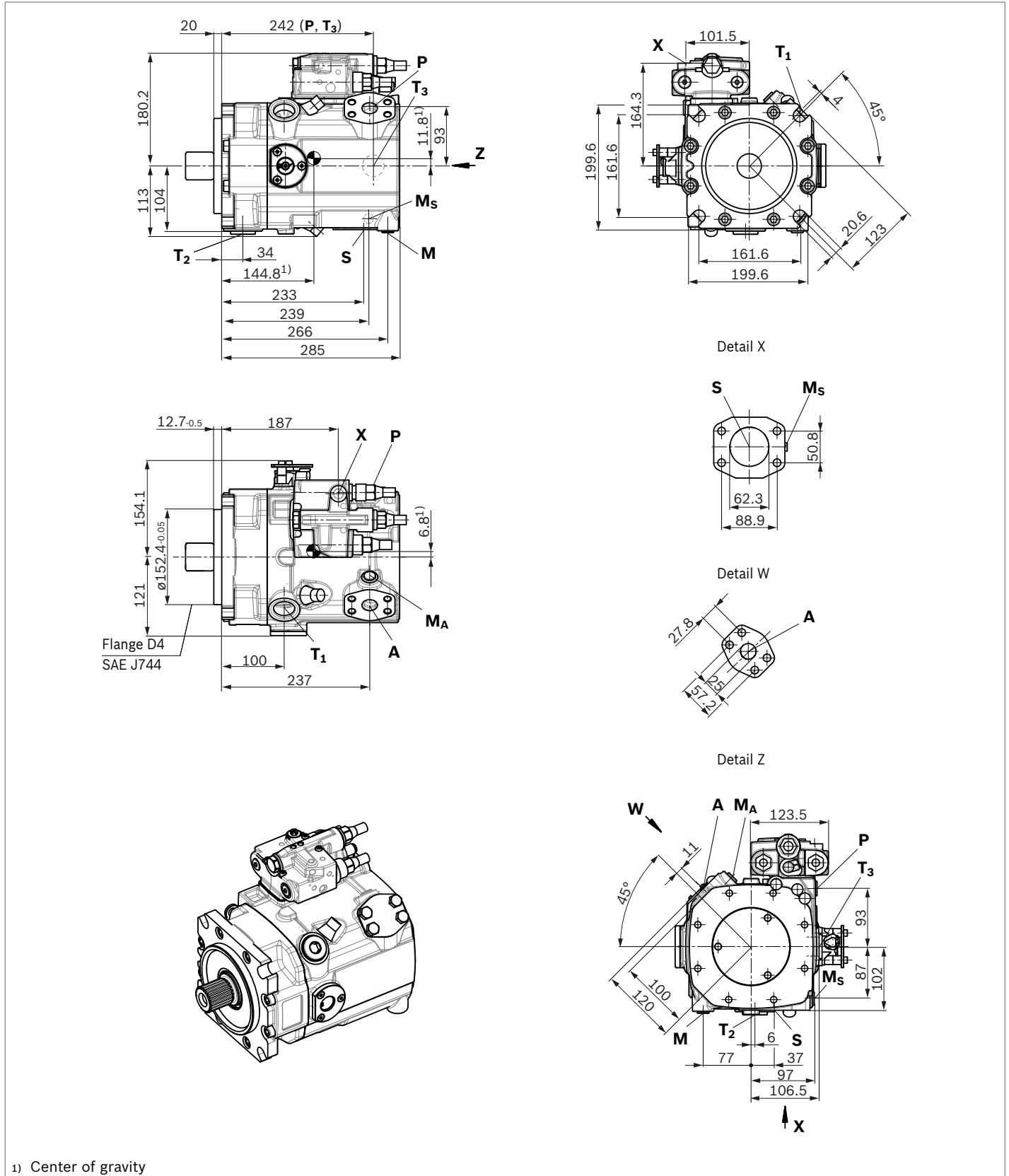

▼ Splined shaft DIN 5480

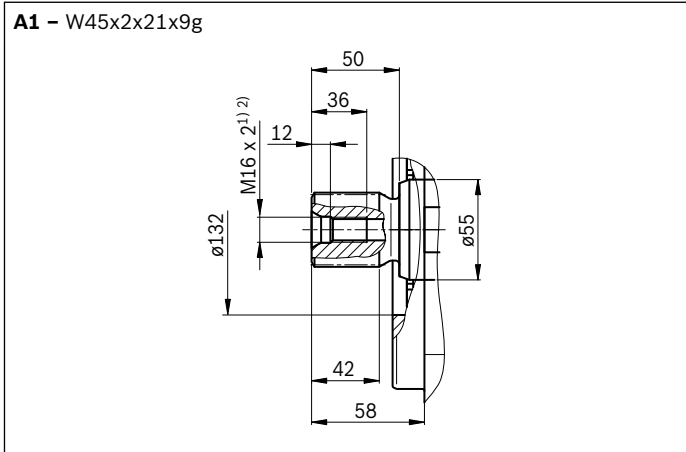

▼ Parallel keyed shaft DIN 6885

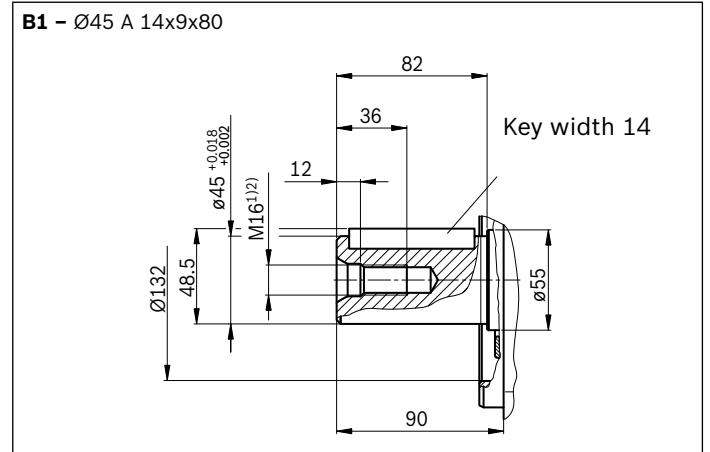

Ports		Standard	Size ²⁾	$p_{\max \text{ abs}}$ [bar] ³⁾	State ⁷⁾
A	Service line port Fastening threads	SAE J518 ⁴⁾ DIN 13	1 in M12 x 2; 18 deep	420	O
S	Suction port (without charge pump) Fastening threads	SAE J518 ⁴⁾ DIN 13	2 1/2 in M12 x 2; 18 deep	30	O
T₁	Drain port	ISO 6149 ⁵⁾	M33 x 2; 19 deep	10	O ⁶⁾
T₂	Drain port	ISO 6149 ⁵⁾	M33 x 2; 19 deep	10	X ⁶⁾
T₃	Drain port	ISO 6149 ⁵⁾	M33 x 2; 19 deep	10	X ⁶⁾
CR	Pilot signal (only on CR)	ISO 6149	M14 x 1.5; 11.5 deep	420	O
PR	Pilot signal (only on PR)	ISO 6149	M14 x 1.5; 11.5 deep	420	O
H3 to H6	Pilot signal (only on H3, H4, H5 and H6)	ISO 6149	M14 x 1.5; 11.5 deep	100	O
DP, DP₁	Pilot pressure (only on DP)	ISO 6149	M14 x 1.5; 11.5 deep	420	O
X	Pilot signal	ISO 6149 ⁵⁾	M14 x 1.5; 11.5 deep	420	O
M	Measuring control pressure	ISO 6149 ⁵⁾	M14 x 1.5; 12 deep	420	X
M_A	Measuring pressure A	ISO 6149 ⁵⁾	M14 x 1.5; 12 deep	420	X
M_S	Measuring suction pressure	ISO 6149 ⁵⁾	M14 x 1.5; 12 deep	30	X
P	External control pressure (ordering code digit 8 version B or C = with external control pressure supply)	ISO 6149 ⁵⁾	M14 x 1.5; 11.5 deep	50	O
	Port P without function (ordering code digit 8 version A = without external control pressure supply)	ISO 6149 ⁵⁾	M18 x 1.5; 14.5 deep	420	X

- Center bore according to DIN 332 (thread according to DIN 13)
- Observe the general instructions on page 58 for the maximum tightening torques.
- Momentary pressure spikes may occur depending on the application. Keep this in mind when selecting measuring devices and fittings.
- Metric fastening threads is a deviation from standard

- The spot face can be deeper than specified in the appropriate standard.
- Depending on installation position, T₁, T₂ or T₃ must be connected (see also installation instructions on pages 56 and 57).
- O = Must be connected (plugged on delivery)
X = Plugged (in normal operation)

▼ **LR – Power controller, fixed setting**

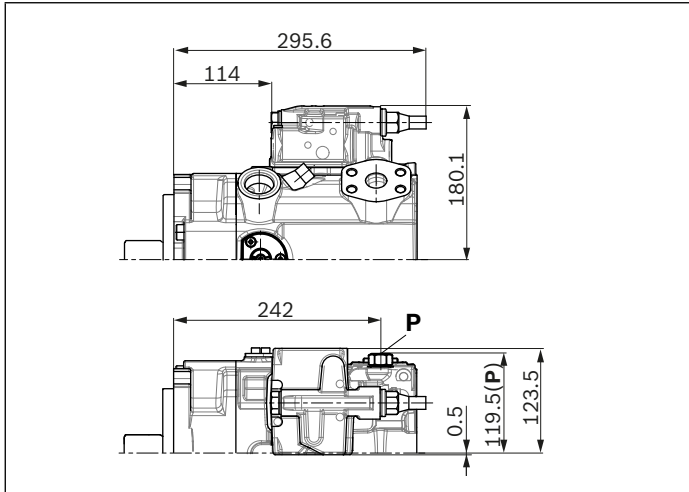

▼ **L4 – Power controller, electric-proportional override**

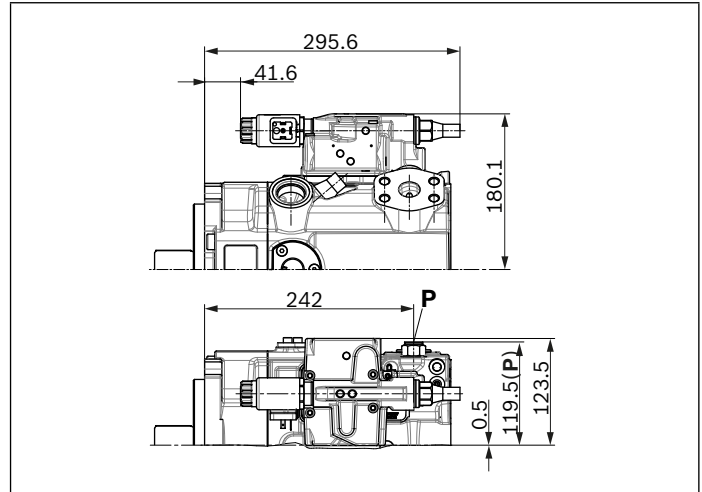

▼ **CR – Power controller, hydraulic-proportional override, high pressure, with stop**

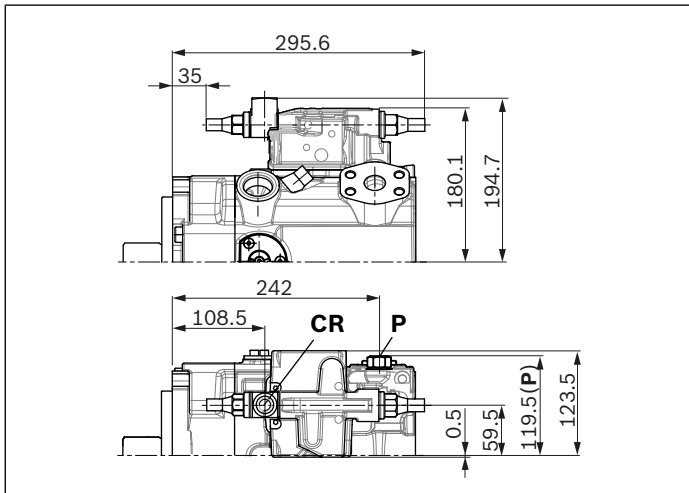

▼ **PR – Power controller, hydraulic-proportional override, high pressure, without stop**

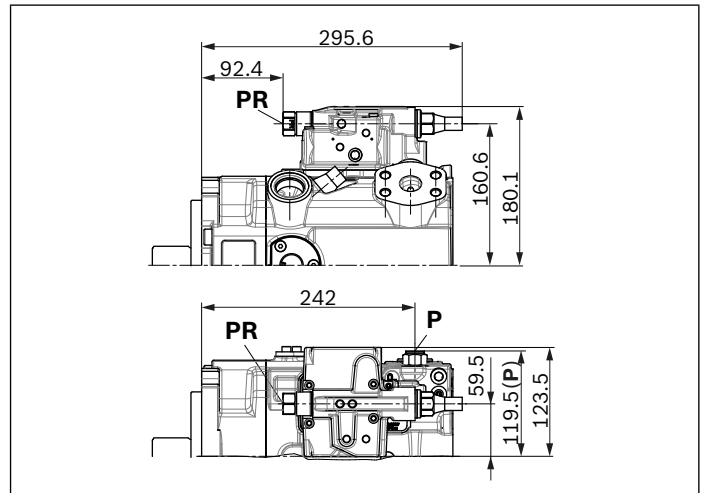

▼ **E2/E6 – Stroke control electric-proportional**

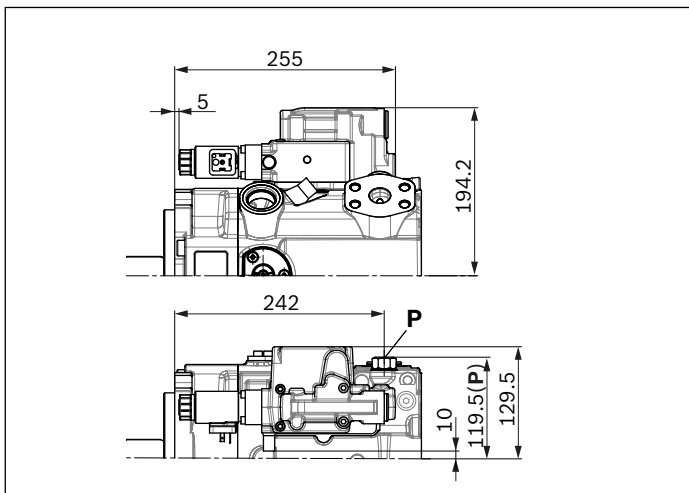

▼ **H3/4/5/6 – Stroke control, hydraulic-prop., pilot pressure**

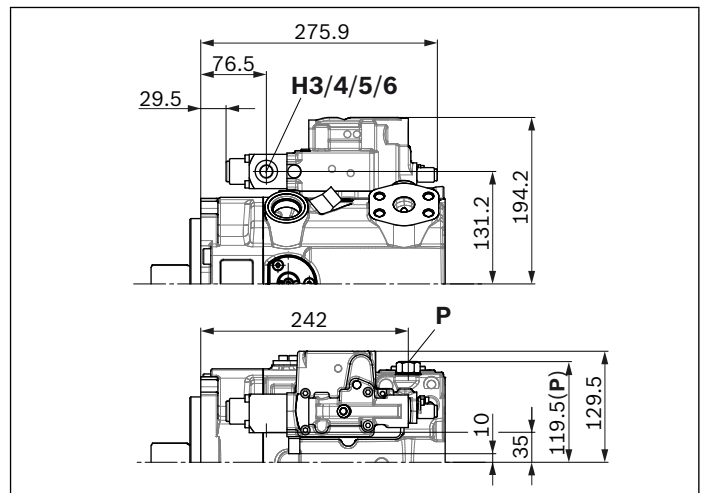

Note

All controllers described with shuttle valve in **P** (some contrary to standard as per ordering code digit 08)

▼ **DR – Pressure controller, fixed setting**

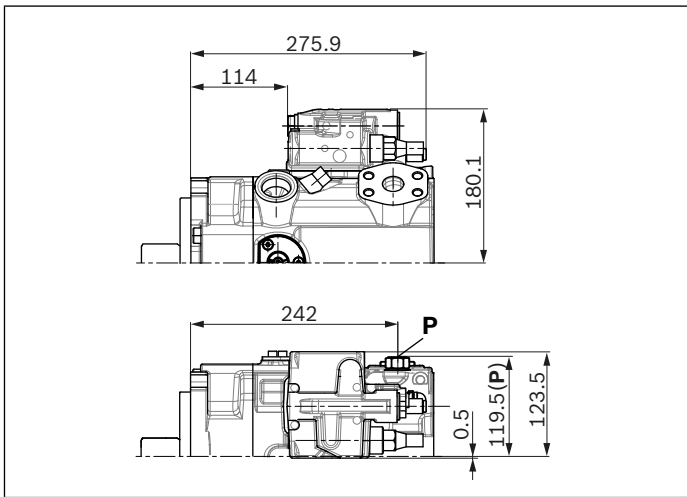

▼ **LRDRS0 – Power controller with pressure controller and load sensing, fixed setting**

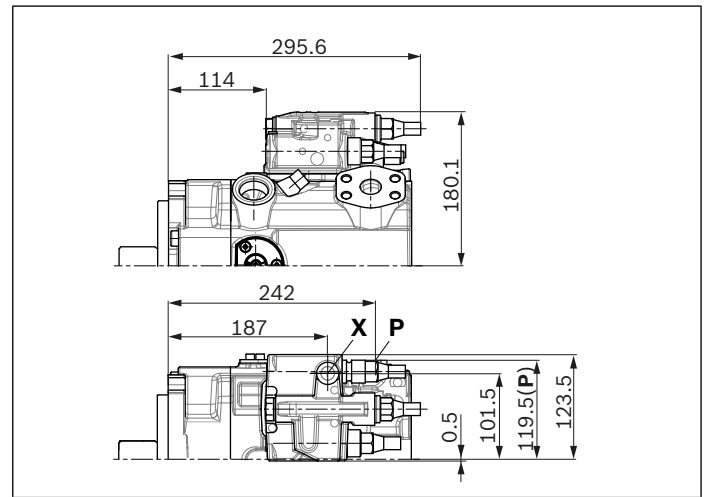

▼ **DG – Pressure controller, hydraulic, remote controlled**

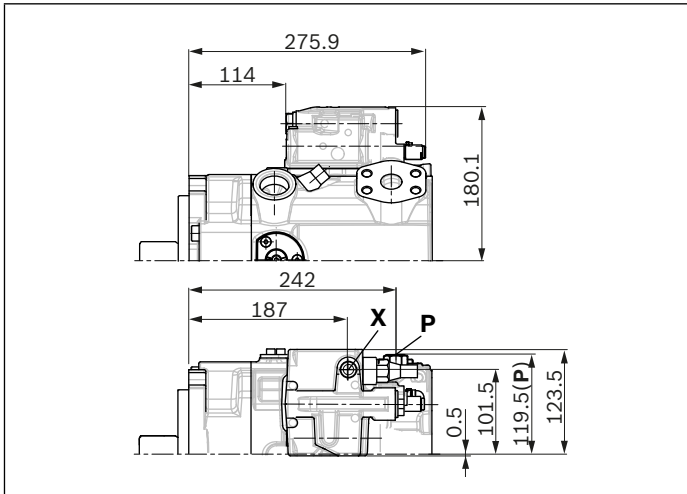

▼ **DP – Pressure controller, for parallel operation**

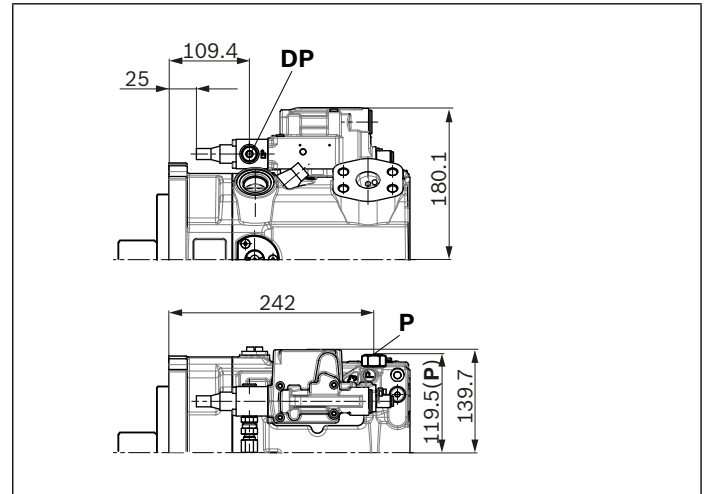

Note

All controllers described with shuttle valve in **P** (some contrary to standard as per ordering code digit 08)

Dimensions size 145

LRDRS0 – Power controller with pressure controller, load sensing and with electric swivel angle sensor

Without charge pump, clockwise rotation

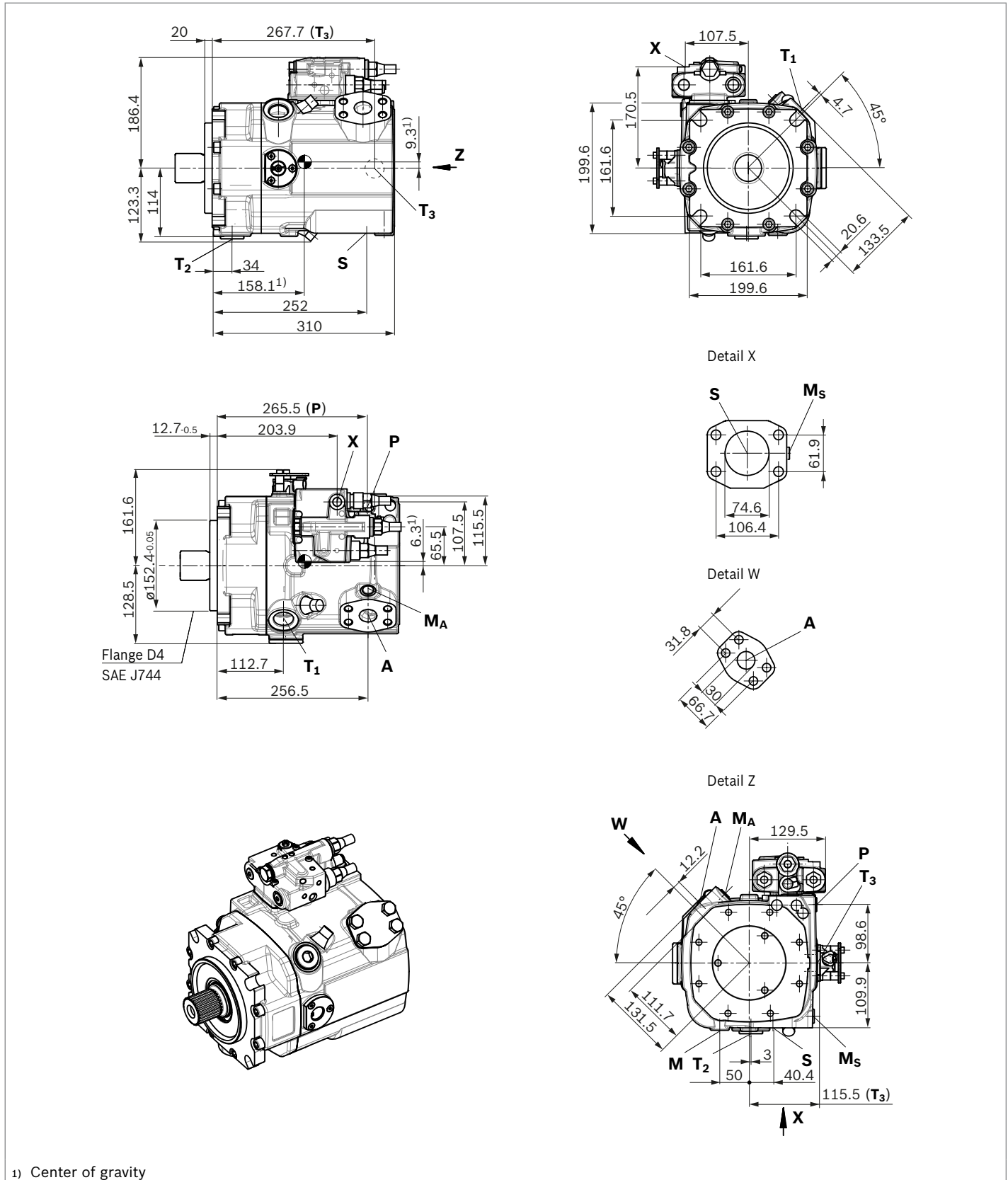

1) Center of gravity

▼ Splined shaft DIN 5480

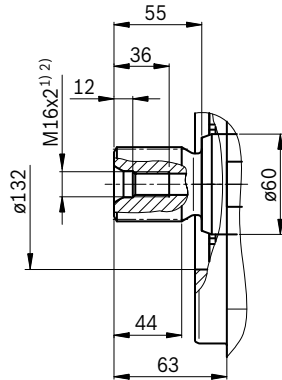
A2 – W50x2x24x9g

▼ Parallel keyed shaft DIN 6885

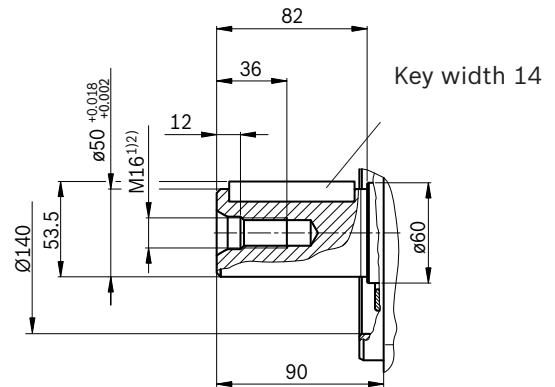
B2 – Ø 50 A 14x9x80

Ports	Standard	Size ²⁾	$p_{\max \text{ abs}}$ [bar] ³⁾	State ⁷⁾
A	Service line port Fastening threads	SAE J518 ⁴⁾ DIN 13	1 1/4 in M14 x 2; 22 deep	420 O
S	Suction port (without charge pump) Fastening threads	SAE J518 ⁴⁾ DIN 13	3 in M16 x 2; 24 deep	30 O
T₁	Drain port	ISO 6149 ⁵⁾	M33 x 2; 19 deep	10 O ⁶⁾
T₂	Drain port	ISO 6149 ⁵⁾	M33 x 2; 19 deep	10 X ⁶⁾
T₃	Drain port	ISO 6149 ⁵⁾	M33 x 2; 19 deep	10 X ⁶⁾
CR	Pilot signal (only on CR)	ISO 6149	M14 x 1.5; 11.5 deep	420 O
PR	Pilot signal (only on PR)	ISO 6149	M14 x 1.5; 11.5 deep	420 O
H3 to H6	Pilot signal (only on H3, H4, H5 and H6)	ISO 6149	M14 x 1.5; 11.5 deep	100 O
DP, DP₁	Pilot pressure (only on DP)	ISO 6149	M14 x 1.5; 11.5 deep	420 O
X	Pilot signal	ISO 6149 ⁵⁾	M14 x 1.5; 11.5 deep	420 O
M	Measuring control pressure	ISO 6149 ⁵⁾	M14 x 1.5; 12 deep	420 X
M_A	Measuring pressure A	ISO 6149 ⁵⁾	M14 x 1.5; 12 deep	420 X
M_S	Measuring suction pressure (only A15VSO)	ISO 6149 ⁵⁾	M14 x 1.5; 12 deep	30 X
P	External control pressure (ordering code digit 8 version B or C = with external control pressure supply)	ISO 6149 ⁵⁾	M14 x 1.5; 11.5 deep	50 O
	Port P without function (ordering code digit 8 version A = without external control pressure supply)	ISO 6149 ⁵⁾	M18 x 1.5; 14.5 deep	420 X

- Center bore according to DIN 332 (thread according to DIN 13)
- Observe the general instructions on page 58 for the maximum tightening torques.
- Momentary pressure spikes may occur depending on the application. Keep this in mind when selecting measuring devices and fittings.
- Metric fastening threads is a deviation from standard

- The spot face can be deeper than specified in the appropriate standard.
- Depending on installation position, T₁, T₂ or T₃ must be connected (see also installation instructions on pages 56 and 57).
- O = Must be connected (plugged on delivery)
X = Plugged (in normal operation)

▼ **LR – Power controller, fixed setting**

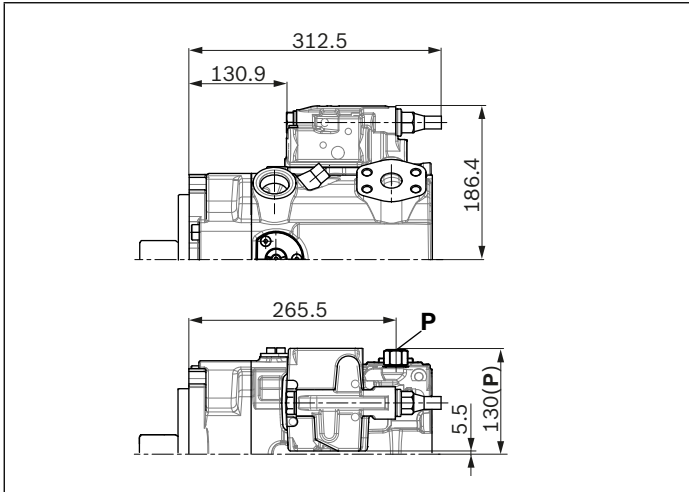

▼ **L4 – Power controller, electric-proportional override**

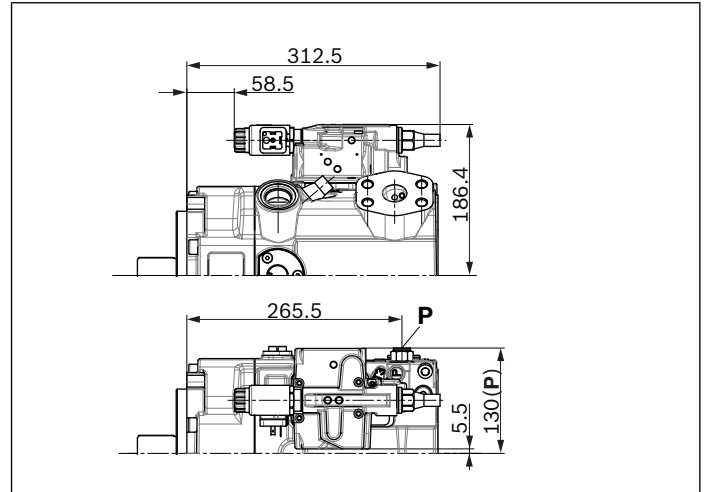

▼ **CR – Power controller, hydraulic-proportional override, high pressure, with stop**

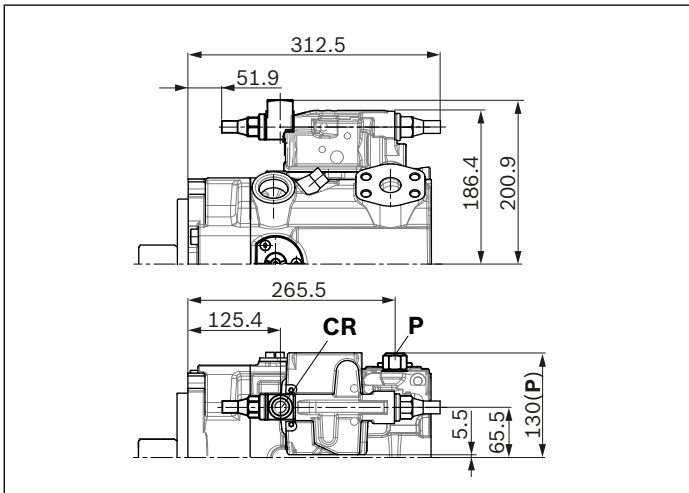

▼ **PR – Power controller, hydraulic-proportional override, high pressure, without stop**

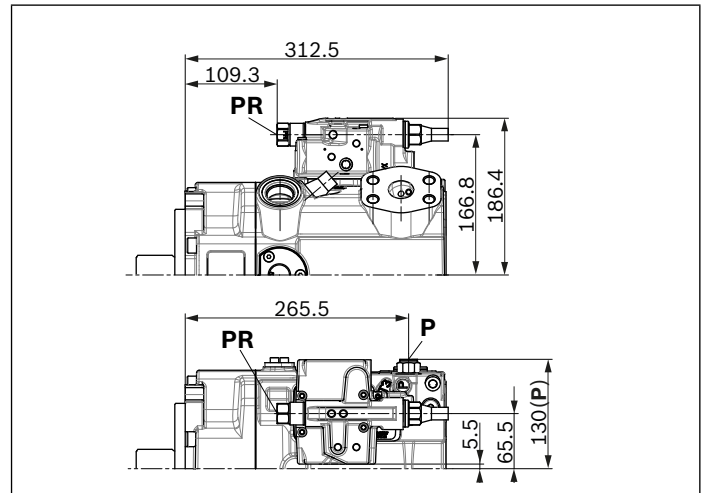

▼ **E2/E6 – Stroke control electric-proportional**

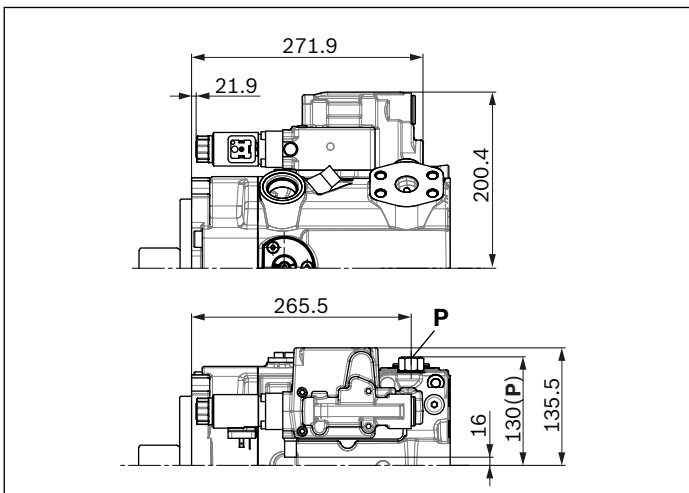

▼ **H3/4/5/6 – Stroke control, hydraulic-prop., pilot pressure**

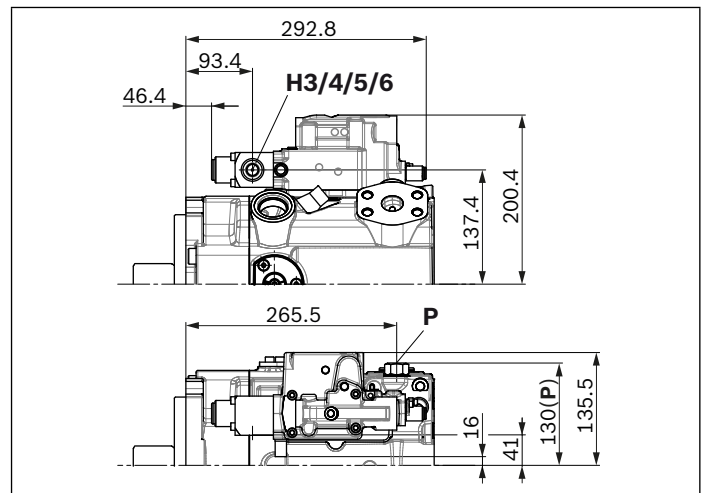

Note

All controllers described with shuttle valve in **P** (some contrary to standard as per ordering code digit 08)

▼ **DR – Pressure controller, fixed setting**

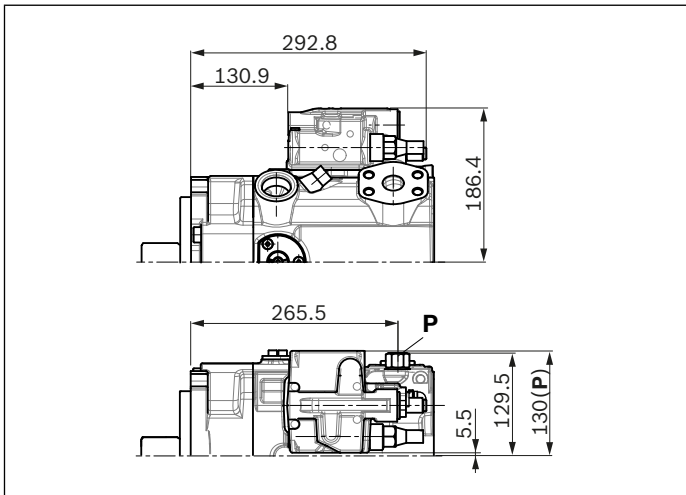

▼ **LRDRS0 – Power controller with pressure controller and load sensing, fixed setting**

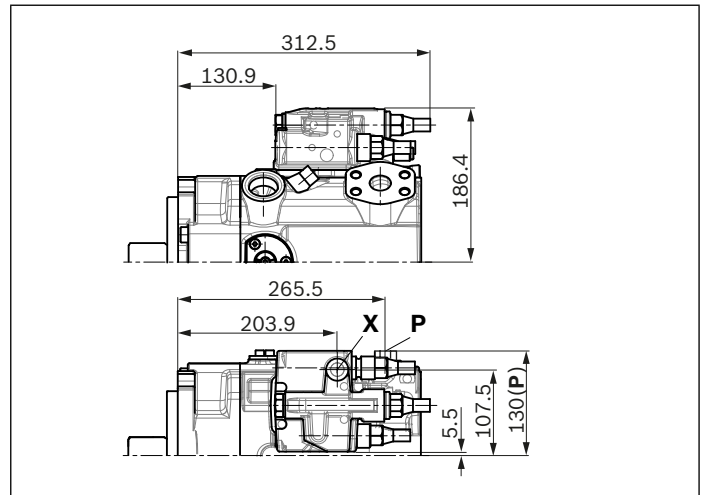

▼ **DG – Pressure controller, hydraulic, remote controlled**

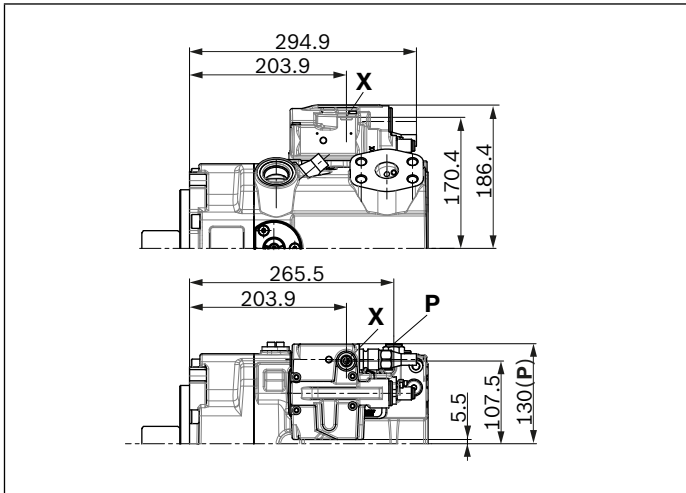

▼ **DP – Pressure controller, for parallel operation**

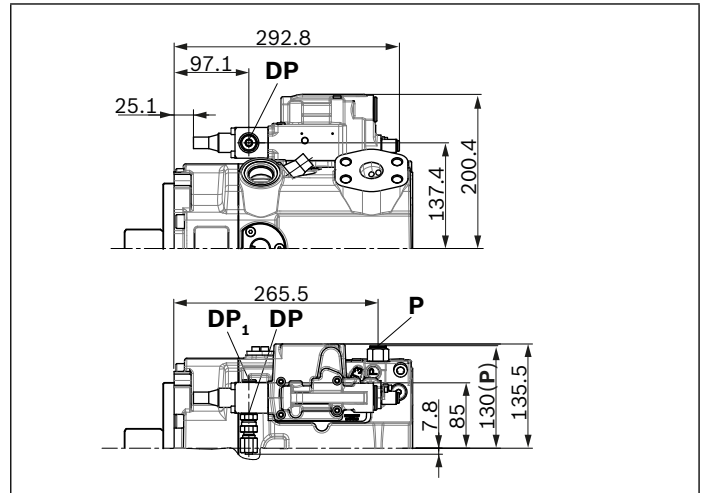

Note

All controllers described with shuttle valve in **P** (some contrary to standard as per ordering code digit 08)

Dimensions size 175

LRDRS0 – Power controller with pressure controller, load sensing and with electric swivel angle sensor

Without charge pump, clockwise rotation

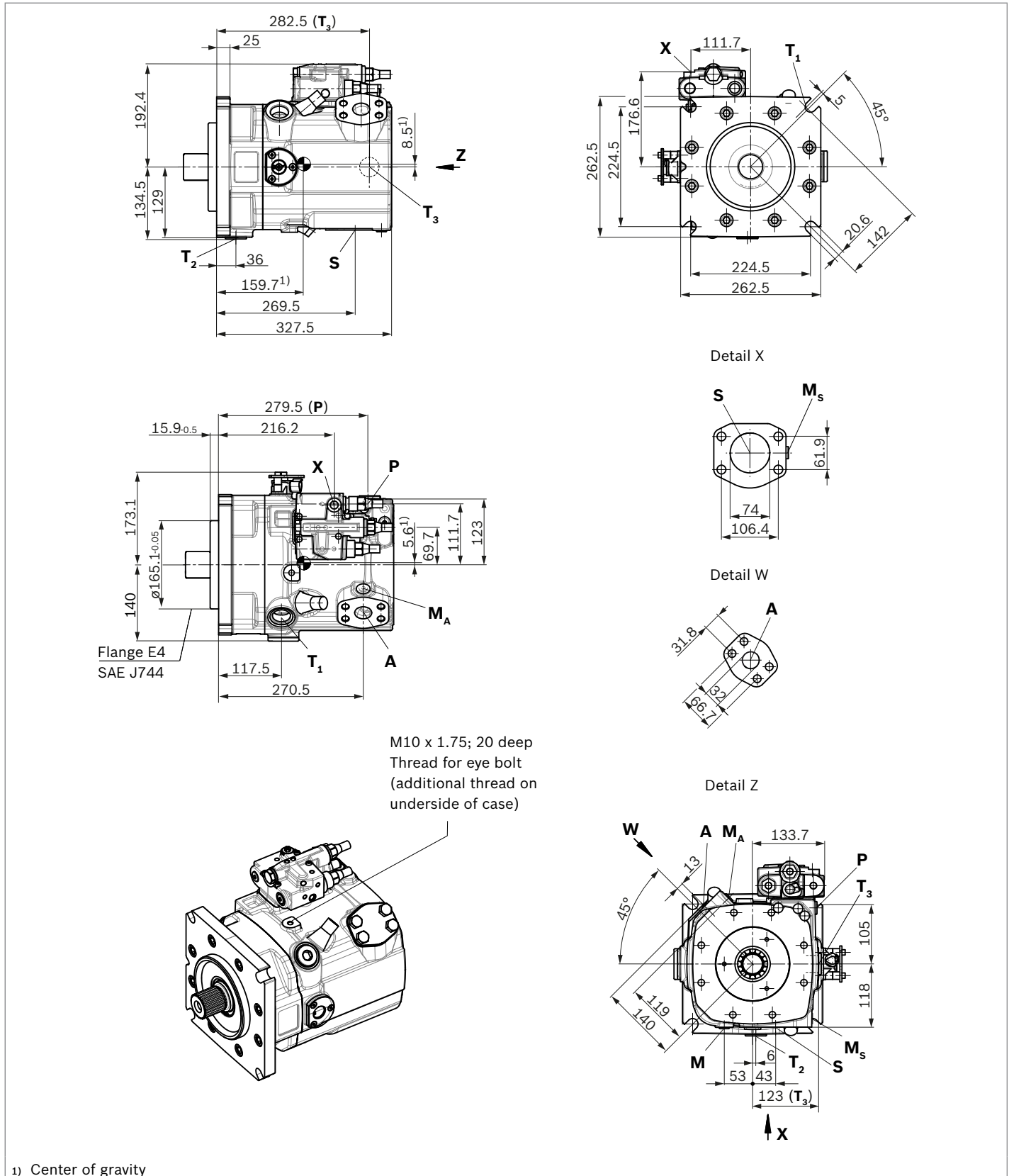

LRDRS0 – Power controller with pressure controller, load sensing and with electric swivel angle sensor

With charge pump, clockwise rotation

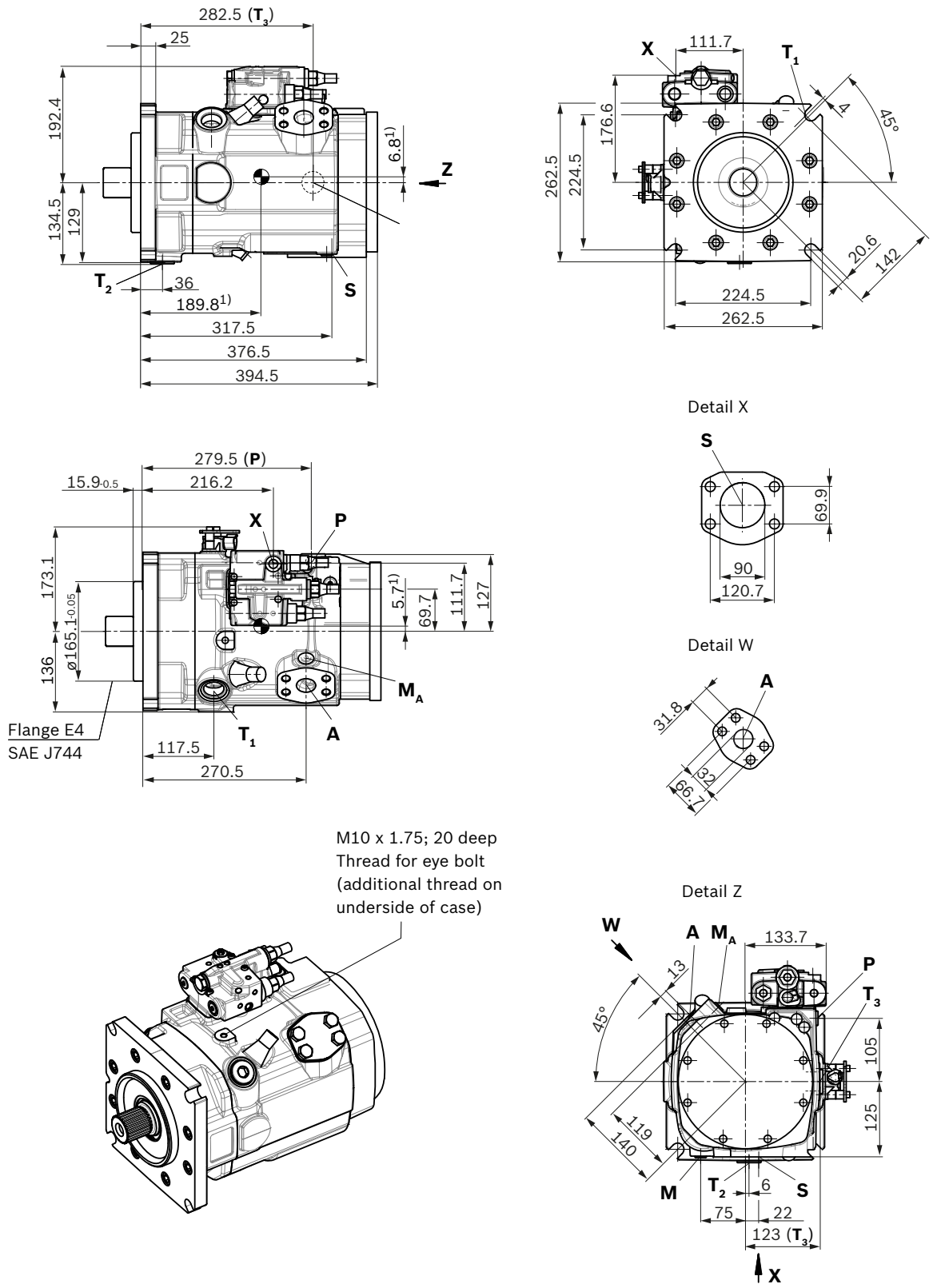

1) Center of gravity

▼ **Splined shaft DIN 5480**

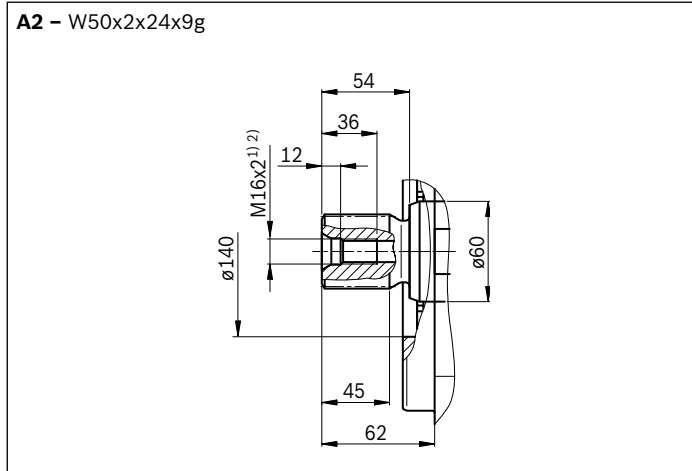

▼ **Parallel keyed shaft DIN 6885**

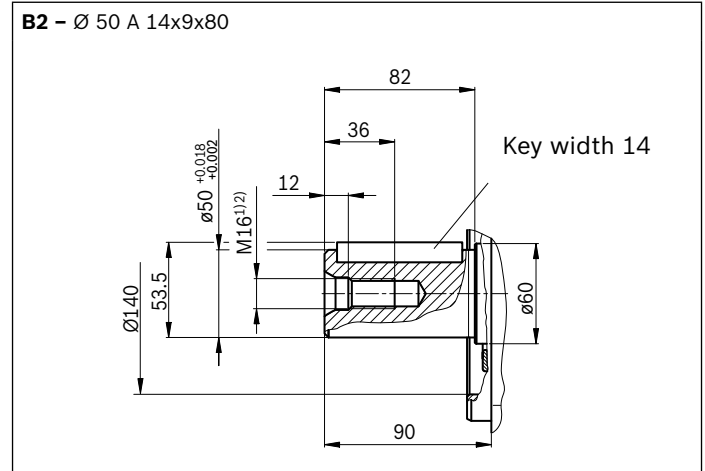

Ports	Standard	Size ²⁾	$p_{\max \text{ abs}}$ [bar] ³⁾	State ⁷⁾
A	Service line port Fastening threads	SAE J518 ⁴⁾ DIN 13	1 1/4 in M14 x 2; 22 deep	420 O
S	Suction port (without charge pump) Fastening threads	SAE J518 ⁴⁾ DIN 13	3 in M16 x 2; 24 deep	30 O
S	Suction port (with charge pump) Fastening threads	SAE J518 ⁴⁾ DIN 13	3 1/2 in M16 x 2; 24 deep	2 O O
T₁	Drain port	ISO 6149 ⁵⁾	M33 x 2; 19 deep	10 O ⁶⁾
T₂	Drain port	ISO 6149 ⁵⁾	M33 x 2; 19 deep	10 X ⁶⁾
T₃	Drain port	ISO 6149 ⁵⁾	M33 x 2; 19 deep	10 X ⁶⁾
CR	Pilot signal (only on CR)	ISO 6149	M14 x 1.5; 11.5 deep	420 O
PR	Pilot signal (only on PR)	ISO 6149	M14 x 1.5; 11.5 deep	420 O
H3 to H6	Pilot signal (only on H3, H4, H5 and H6)	ISO 6149	M14 x 1.5; 11.5 deep	100 O
X	Pilot signal	ISO 6149 ⁵⁾	M14 x 1.5; 11.5 deep	420 O
DP, DP₁	Pilot pressure (only on DP)	ISO 6149	M14 x 1.5; 11.5 deep	420 O
M	Measuring control pressure	ISO 6149 ⁵⁾	M14 x 1.5; 12 deep	420 X
M_A	Measuring pressure A	ISO 6149 ⁵⁾	M14 x 1.5; 12 deep	420 X
M_S	Measuring suction pressure (only A15VSO)	ISO 6149 ⁵⁾	M14 x 1.5; 12 deep	30 X
P	External control pressure (ordering code digit 8 version B or C = with external control pressure supply)	ISO 6149 ⁵⁾	M14 x 1.5; 11.5 deep	50 O
	Port P without function (ordering code digit 8 version A = without external control pressure supply)	ISO 6149 ⁵⁾	M18 x 1.5; 14.5 deep	420 X

1) Center bore according to DIN 332 (thread according to DIN 13)
 2) Observe the general instructions on page 58 for the maximum tightening torques.
 3) Momentary pressure spikes may occur depending on the application. Keep this in mind when selecting measuring devices and fittings.
 4) Metric fastening threads is a deviation from standard

5) The spot face can be deeper than specified in the appropriate standard.
 6) Depending on installation position, T₁, T₂ or T₃ must be connected (see also installation instructions on pages 56 and 57).
 7) O = Must be connected (plugged on delivery)
 X = Plugged (in normal operation)

▼ **LR – Power controller, fixed setting**

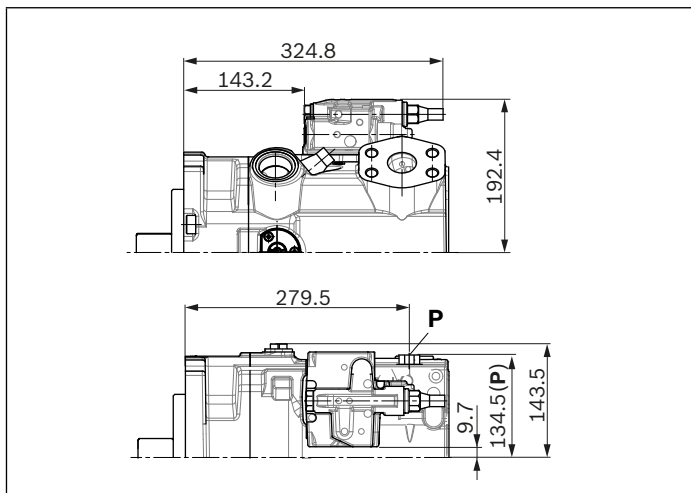

▼ **L4 – Power controller, electric-proportional override**

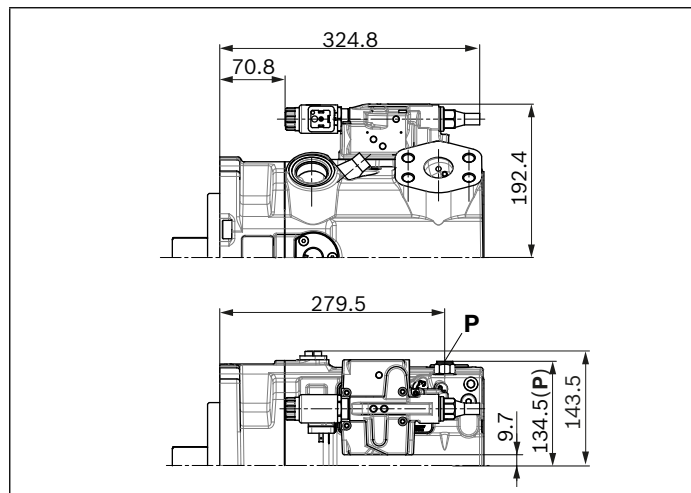

▼ **CR – Power controller, hydraulic-proportional override, high pressure, with stop**

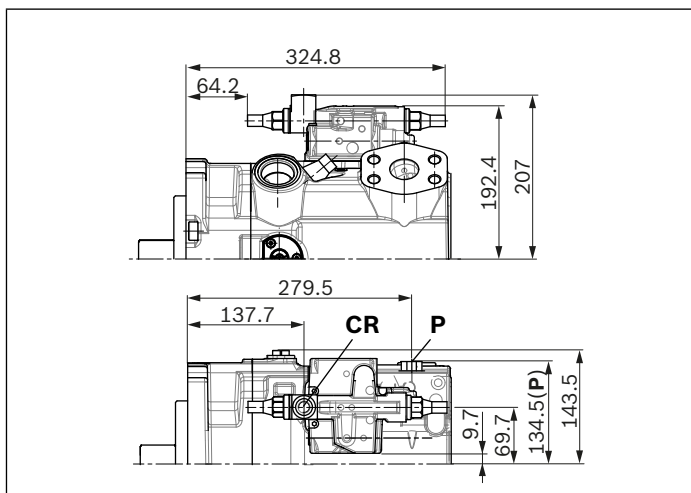

▼ **PR – Power controller, hydraulic-proportional override, high pressure, without stop**

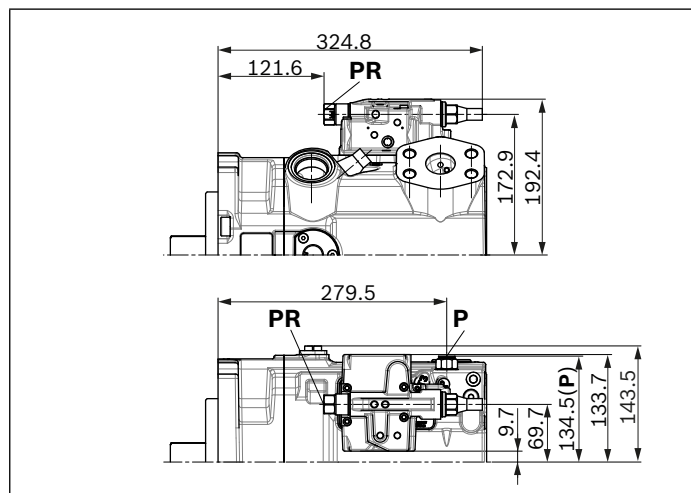

▼ **E2/E6 – Stroke control electric-proportional**

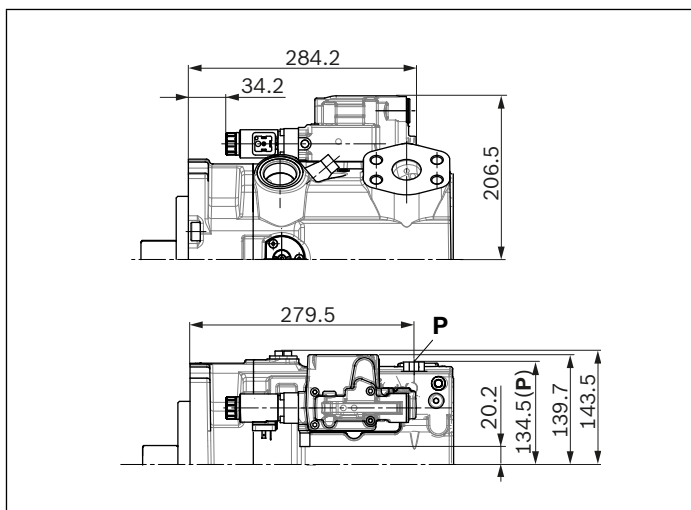

▼ **H3/4/5/6 – Stroke control, hydraulic-prop., pilot pressure**

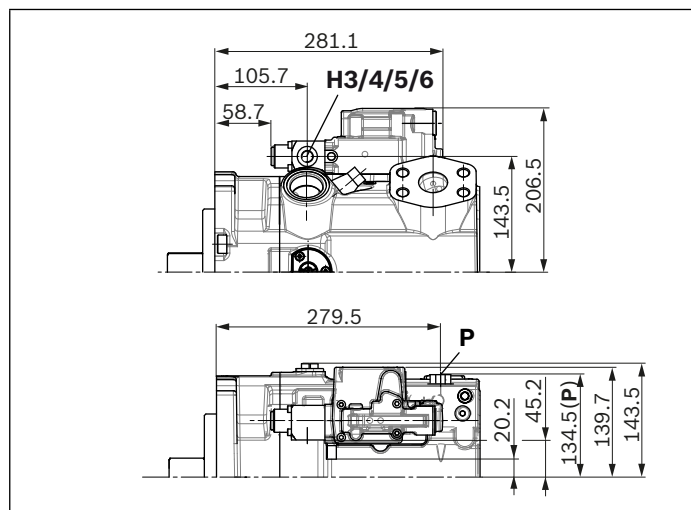

Note

All controllers described with shuttle valve in **P** (some contrary to standard as per ordering code digit 08)

▼ **DR – Pressure controller, fixed setting**

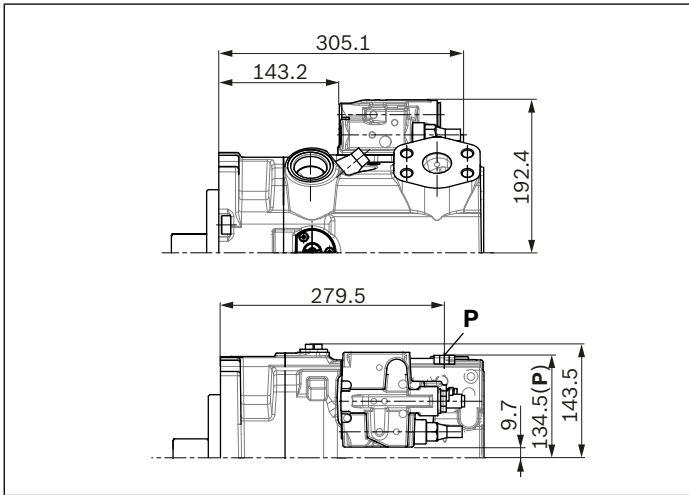

▼ **LRDRSO – Power controller with pressure controller and load sensing, fixed setting**

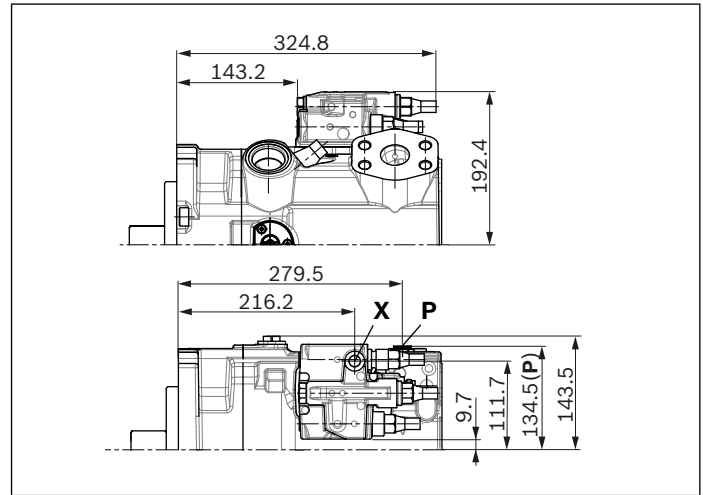

▼ **DG – Pressure controller, hydraulic, remote controlled**

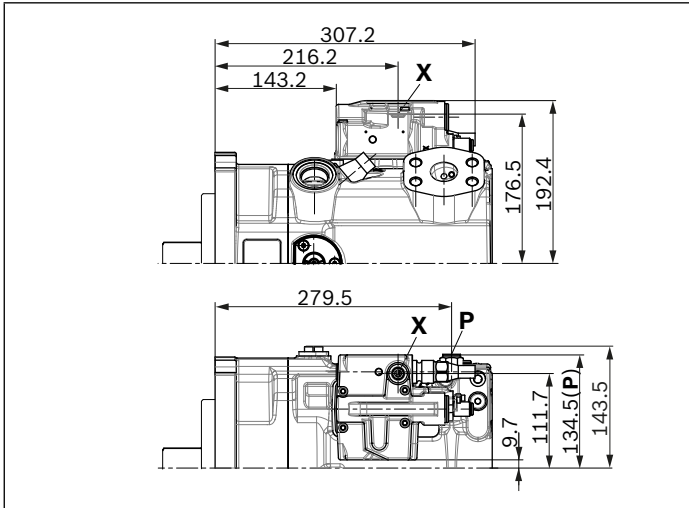

▼ **DP – Pressure controller, for parallel operation**

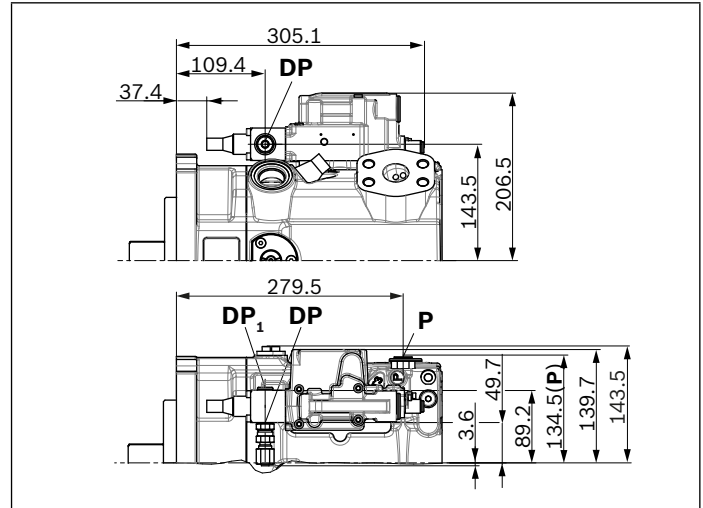

Note

All controllers described with shuttle valve in **P** (some contrary to standard as per ordering code digit 08)

Dimensions size 210

LRDRS0 – Power controller with pressure controller, load sensing and with electric swivel angle sensor
 Without charge pump, clockwise rotation

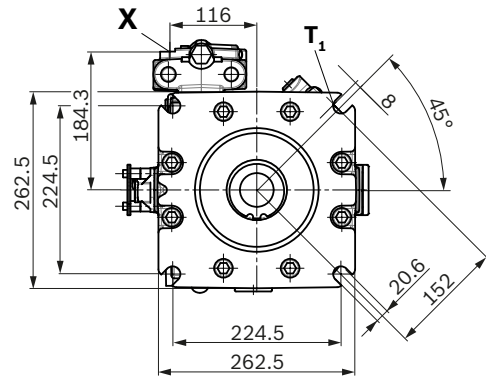
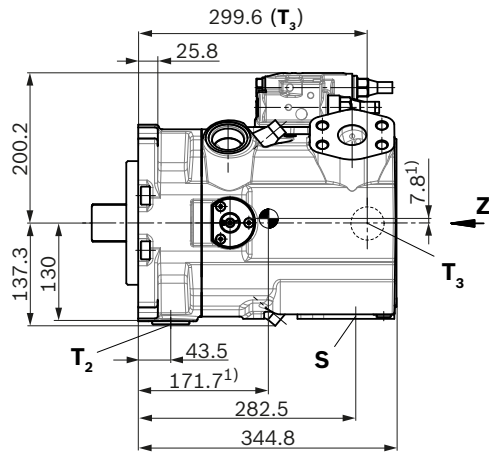

Detail X

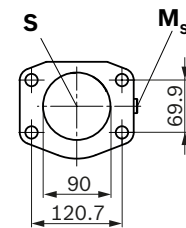

Detail W

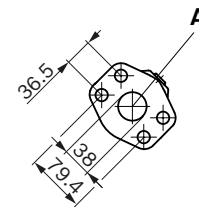

Detail Z

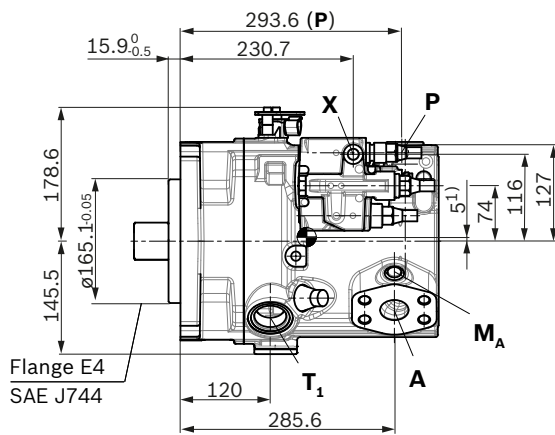
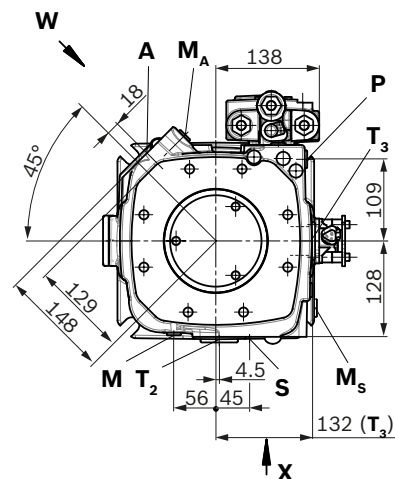

M12 x 1.75; 22 deep
 Thread for eye bolt
 (additional thread on
 underside of case)

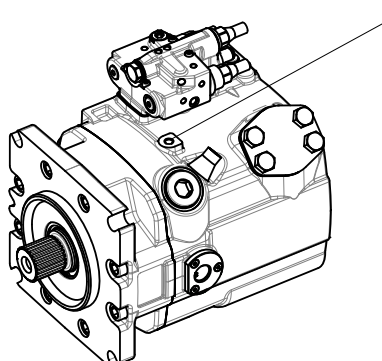

1) Center of gravity

LRDRS0 – Power controller with pressure controller, load sensing and with electric swivel angle sensor

With charge pump, clockwise rotation

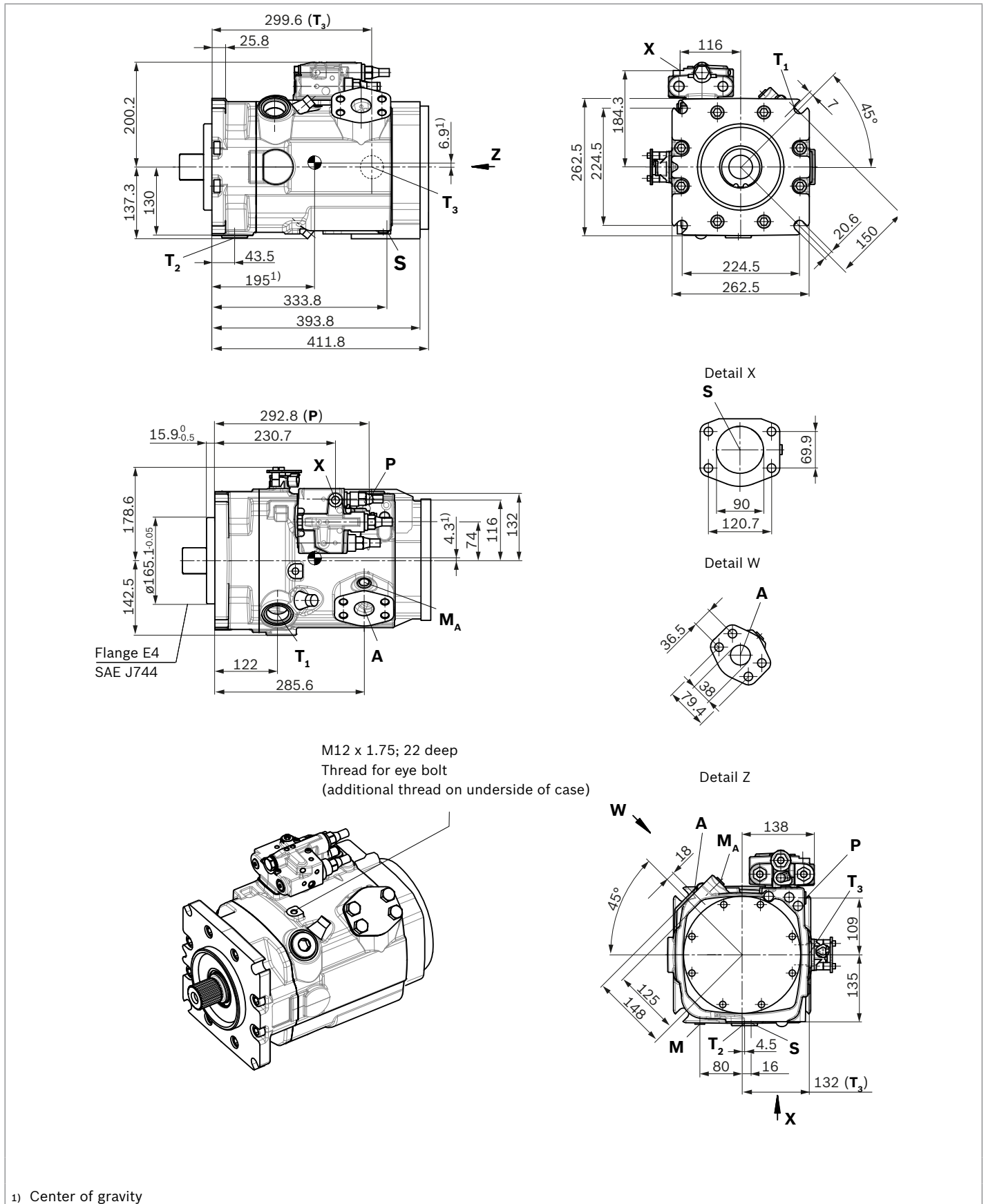

▼ Splined shaft DIN 5480

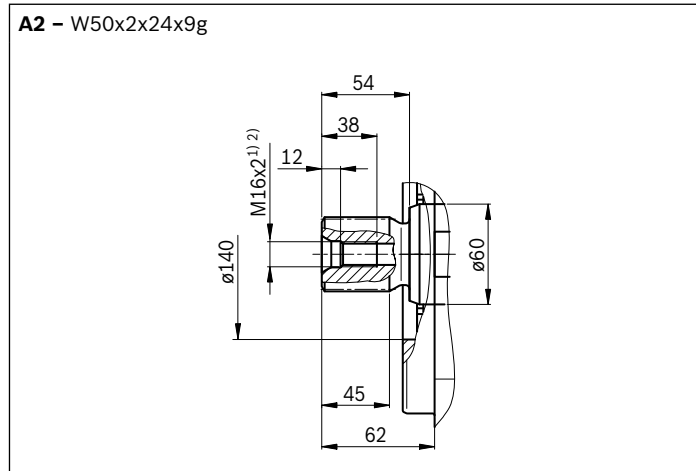

▼ Parallel keyed shaft DIN 5480

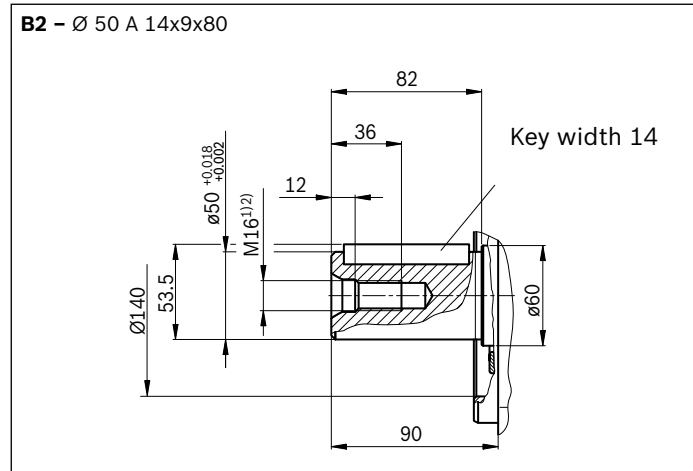

Ports	Standard	Size ²⁾	$p_{\max \text{ abs}}$ [bar] ³⁾	State ⁷⁾
A	Service line port Fastening threads	SAE J518 ⁴⁾ DIN 13	1 1/2 in M16 x 2; 21 deep	420 O
S	Suction port (without charge pump) Fastening threads	SAE J518 ⁴⁾ DIN 13	3 1/2 in M16 x 2; 24 deep	30 O
S	Suction port (with charge pump) Fastening threads	SAE J518 ⁴⁾ DIN 13	3 1/2 in M16 x 2; 24 deep	2 O
T₁	Drain port	ISO 6149 ⁵⁾	M42 x 2; 19.5 deep	10 O ⁶⁾
T₂	Drain port	ISO 6149 ⁵⁾	M42 x 2; 19.5 deep	10 X ⁶⁾
T₃	Drain port	ISO 6149 ⁵⁾	M42 x 2; 19.5 deep	10 X ⁶⁾
CR	Pilot signal (only on CR)	ISO 6149	M14 x 1.5; 11.5 deep	420 O
PR	Pilot signal (only on PR)	ISO 6149	M14 x 1.5; 11.5 deep	420 O
H3 to H6	Pilot signal (only on H3, H4, H5 and H6)	ISO 6149	M14 x 1.5; 11.5 deep	100 O
X	Pilot signal	ISO 6149 ⁵⁾	M14 x 1.5; 11.5 deep	420 O
DP, DP₁	Pilot pressure (only on DP)	ISO 6149	M14 x 1.5; 11.5 deep	420 O
M	Measuring control pressure	ISO 6149 ⁵⁾	M14 x 1.5; 12 deep	420 X
M_A	Measuring pressure A	ISO 6149 ⁵⁾	M14 x 1.5; 12 deep	420 X
M_S	Measuring suction pressure (only A15VSO)	ISO 6149 ⁵⁾	M14 x 1.5; 12 deep	30 X
P	External control pressure (ordering code digit 8 version B or C = with external control pressure supply)	ISO 6149 ⁵⁾	M14 x 1.5; 11.5 deep	50 O
	Port P without function (ordering code digit 8 version A = without external control pressure supply)	ISO 6149 ⁵⁾	M14 x 1.5; 11.5 deep	420 X

- Center bore according to DIN 332 (thread according to DIN 13)
- Observe the general instructions on page 58 for the maximum tightening torques.
- Momentary pressure spikes may occur depending on the application. Keep this in mind when selecting measuring devices and fittings.
- Metric fastening threads is a deviation from standard

- The spot face can be deeper than specified in the appropriate standard.
- Depending on installation position, T₁, T₂ or T₃ must be connected (see also installation instructions on pages 56 and 57).
- O = Must be connected (plugged on delivery)
X = Plugged (in normal operation)

▼ **LR – Power controller, fixed setting**

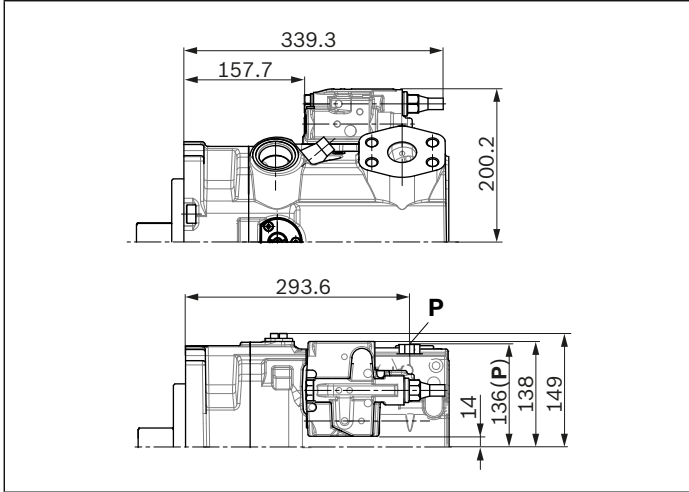

▼ **L4 – Power controller, electric-proportional override**

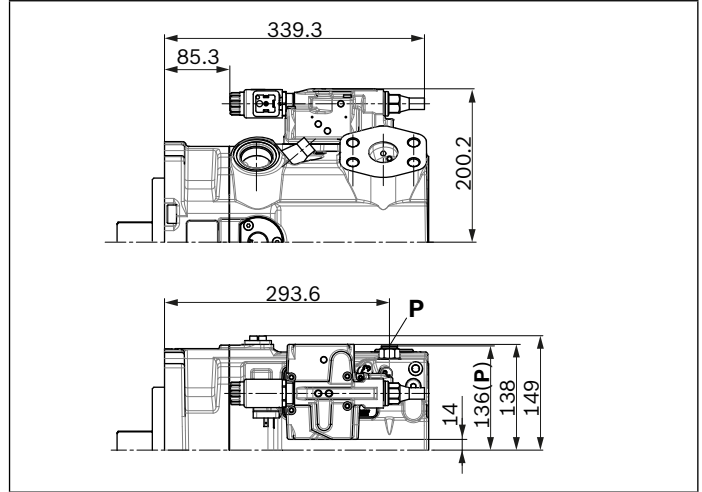

▼ **CR – Power controller, hydraulic-proportional override, high pressure, with stop**

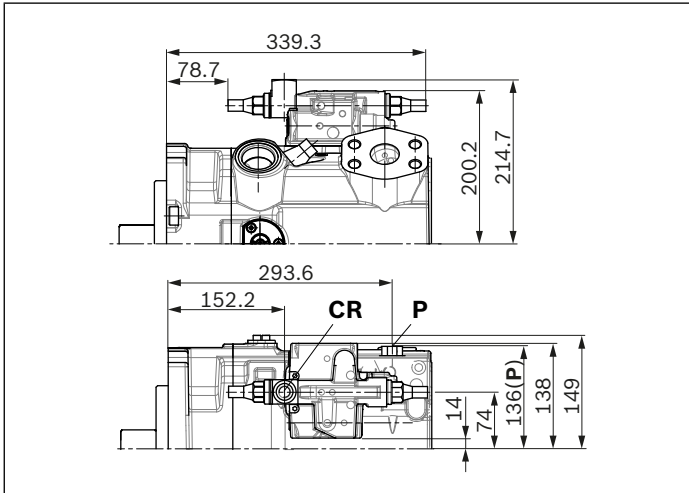

▼ **PR – Power controller, hydraulic-proportional override, high pressure, without stop**

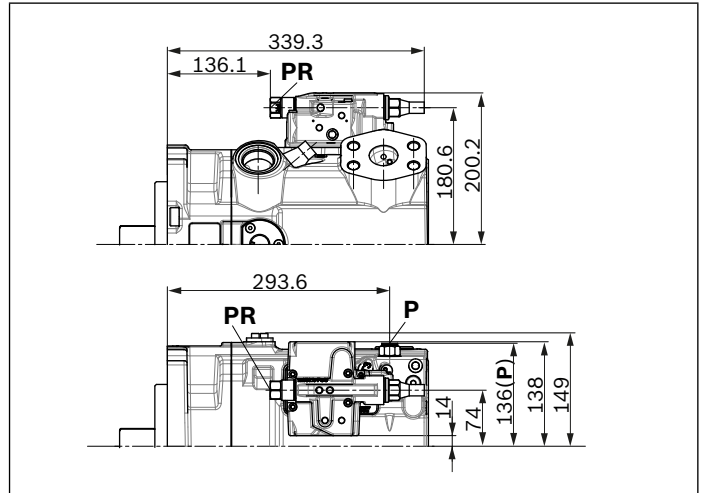

▼ **E2/E6 – Stroke control electric-proportional**

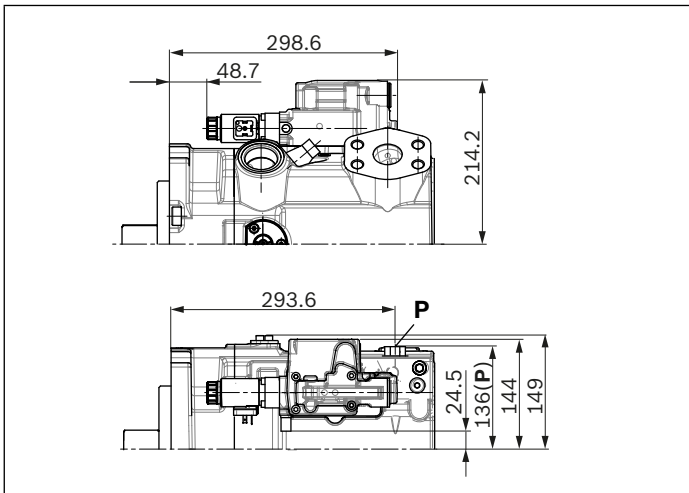

▼ **H3/4/5/6 – Stroke control, hydraulic-prop., pilot pressure**

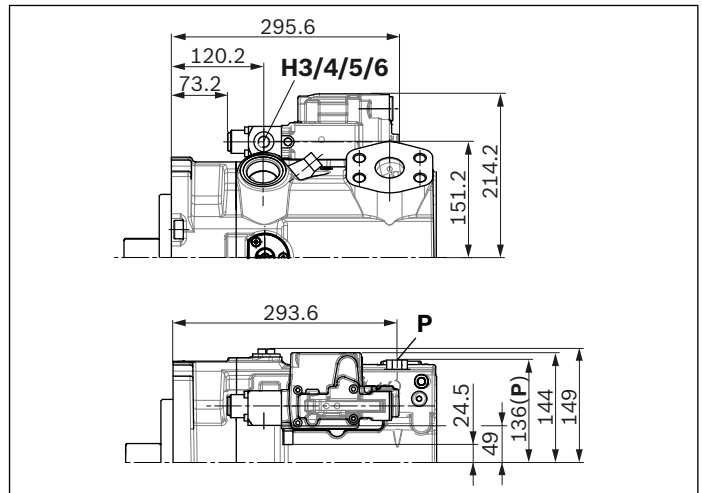

Note

All controllers described with shuttle valve in **P** (some contrary to standard as per ordering code digit 08)

▼ **DR – Pressure controller, fixed setting**

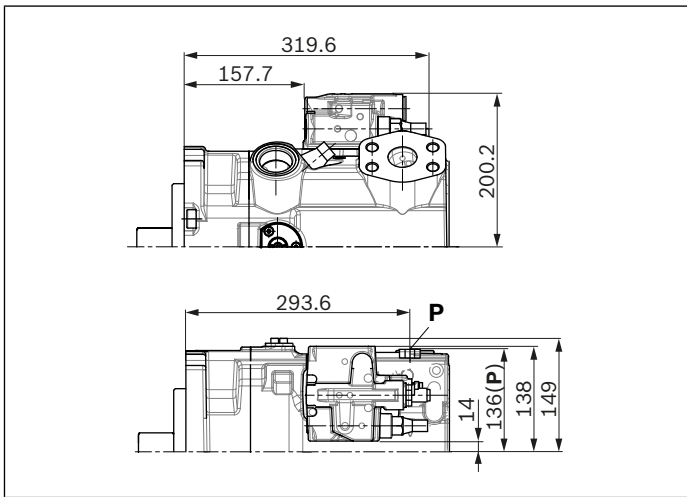

▼ **LRDRS0 – Power controller with pressure controller and load sensing, fixed setting**

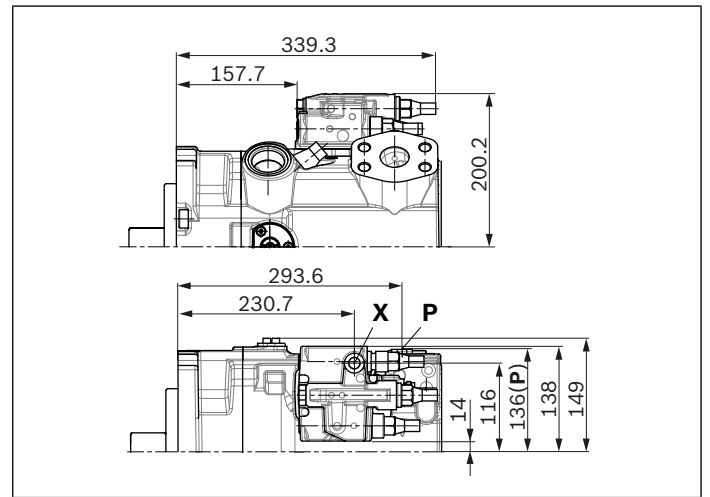

▼ **DG – Pressure controller, hydraulic, remote controlled**

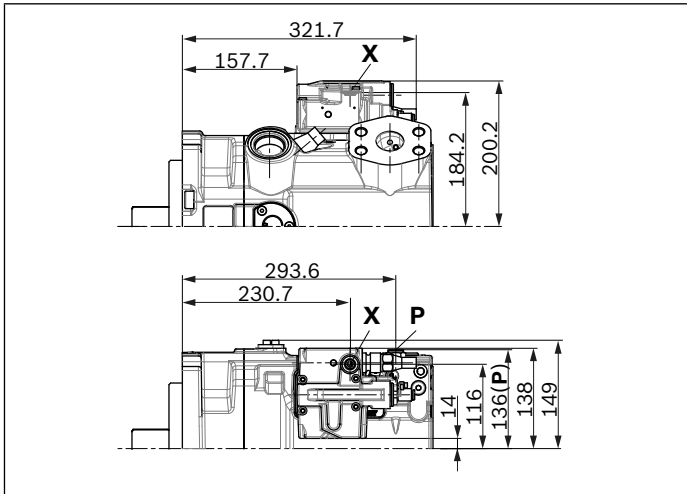

▼ **DP – Pressure controller, for parallel operation**

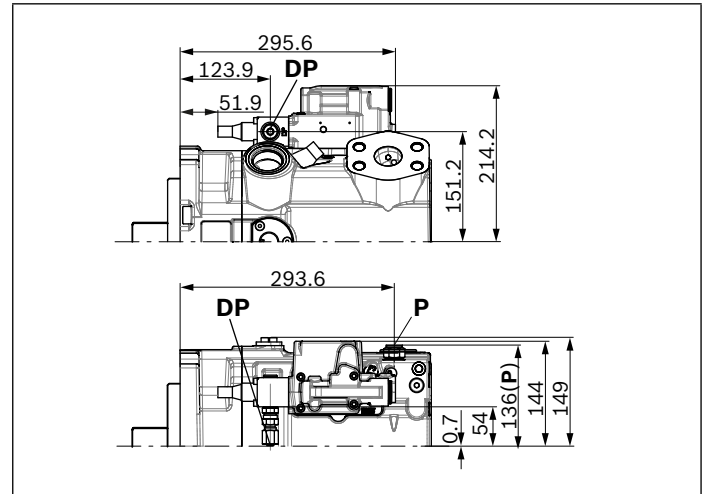

Note

All controllers described with shuttle valve in **P** (some contrary to standard as per ordering code digit 08)

Dimensions size 280

LRDRS0 – Power controller with pressure controller, load sensing and with electric swivel angle sensor

Without charge pump, clockwise rotation

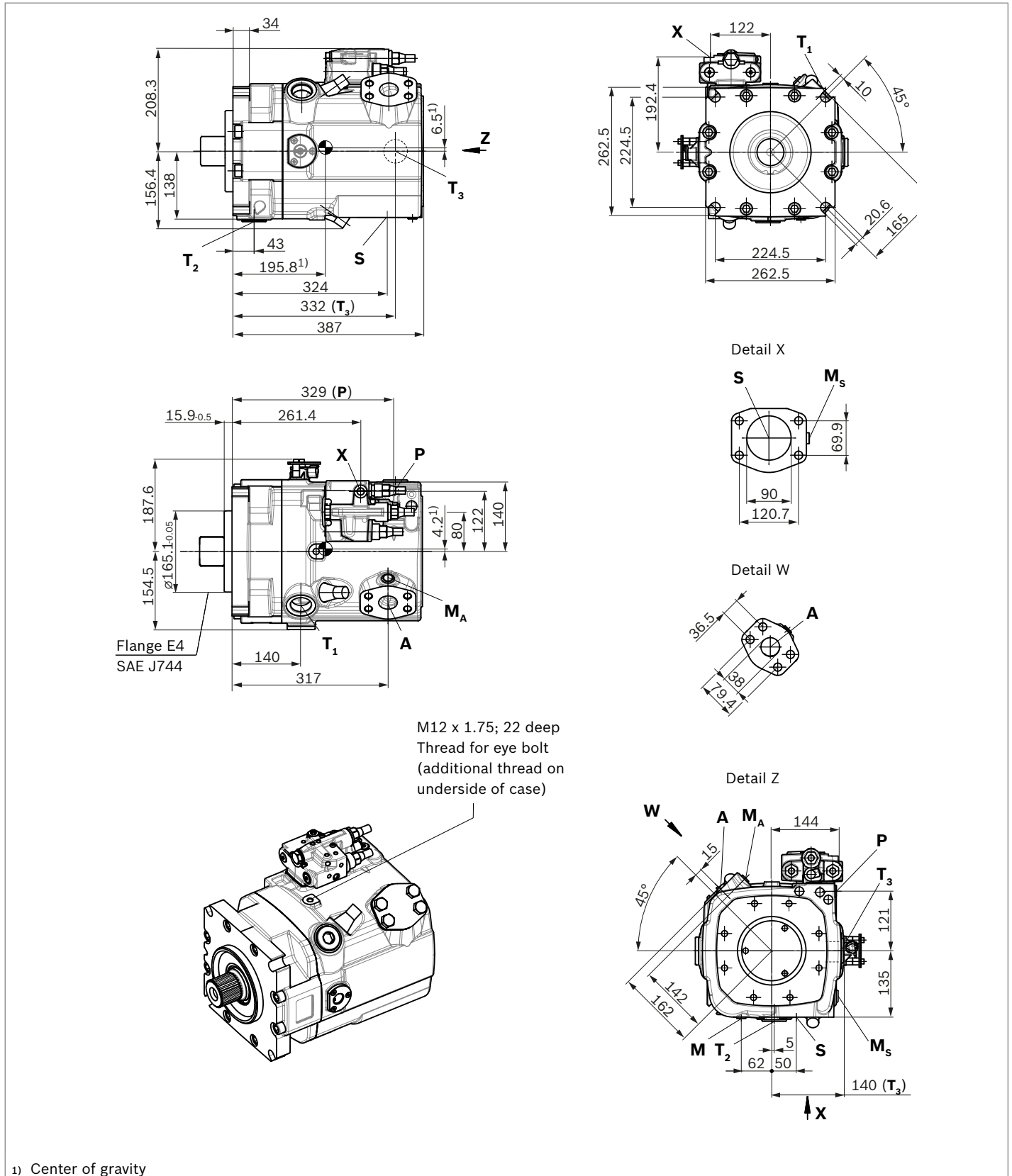

LRDRS0 – Power controller with pressure controller, load sensing and with electric swivel angle sensor

With charge pump, clockwise rotation

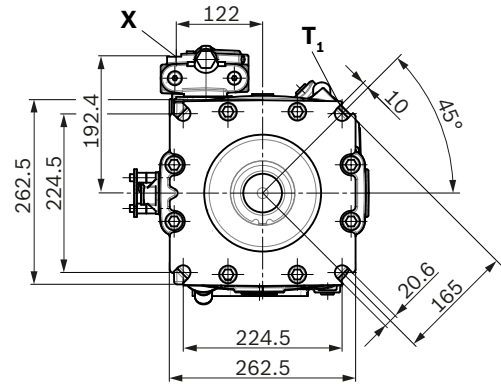
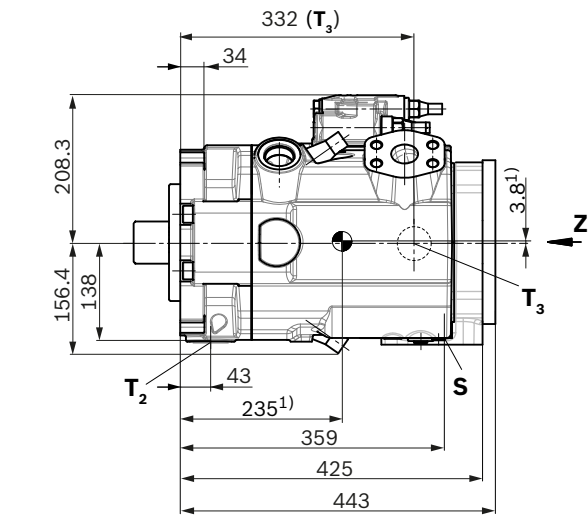

Detail X

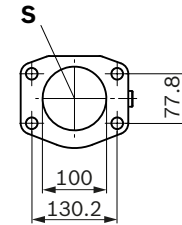

Detail W

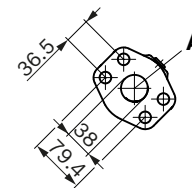

Detail Z

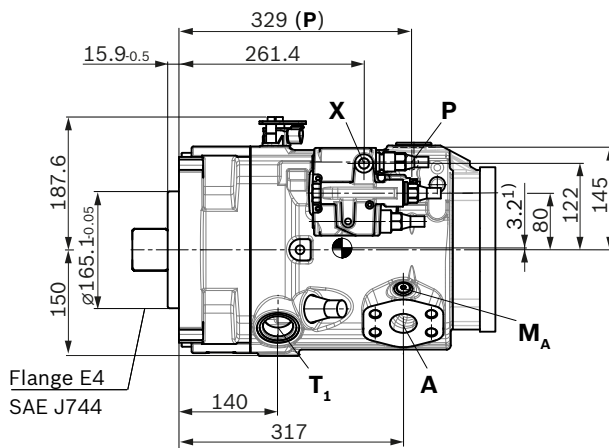
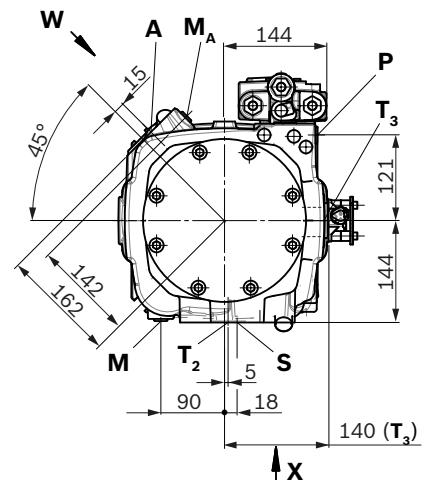

M12 x 1.75; 22 deep
 Thread for eye bolt
 (additional thread on
 underside of case)

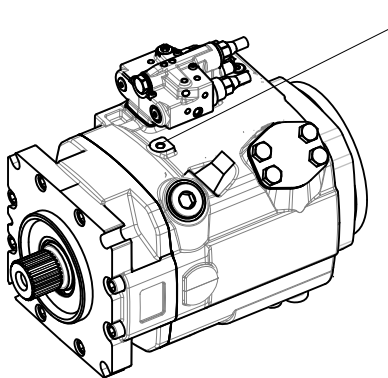

1) Center of gravity

▼ **Splined shaft DIN 5480**

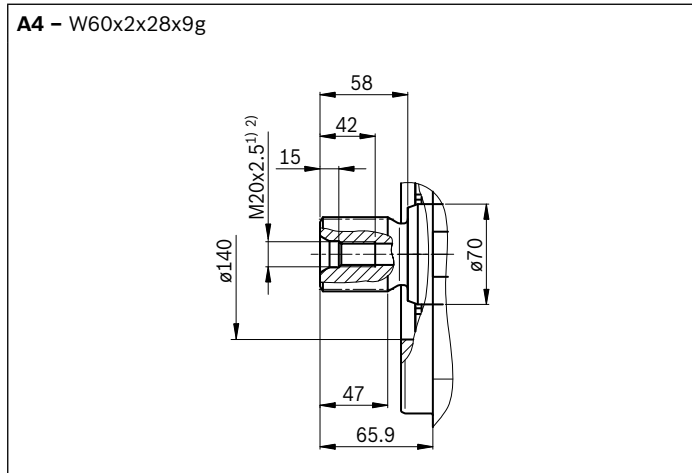

▼ **Parallel keyed shaft DIN 6885**

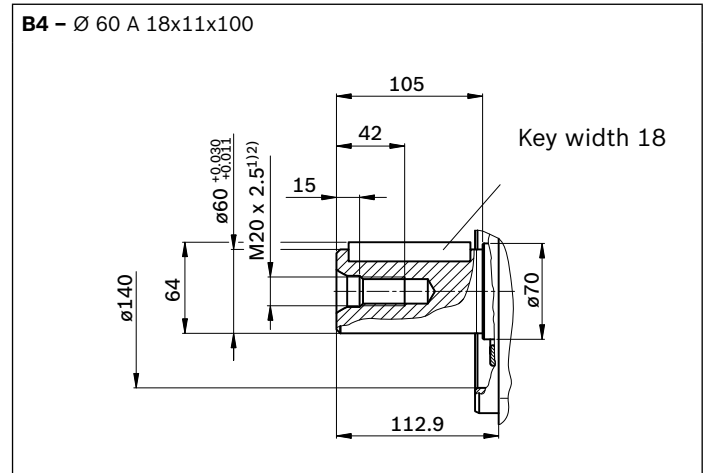

Ports	Standard	Size ²⁾	$p_{\max \text{ abs}}$ [bar] ³⁾	State ⁷⁾
A	Service line port Fastening threads	SAE J518 ⁴⁾ DIN 13	1 1/2 in M16 x 2; 21 deep	420 O
S	Suction port (without charge pump) Fastening threads	SAE J518 ⁴⁾ DIN 13	3 1/2 in M16 x 2; 24 deep	30 O
S	Suction port (with charge pump) Fastening threads	SAE J518 ⁴⁾ DIN 13	4 in M16 x 2; 24 deep	2 O
T₁	Drain port	ISO 6149 ⁵⁾	M42 x 2; 19.5 deep	10 O ⁶⁾
T₂	Drain port	ISO 6149 ⁵⁾	M42 x 2; 19.5 deep	10 X ⁶⁾
T₃	Drain port	ISO 6149 ⁵⁾	M42 x 2; 19.5 deep	10 X ⁶⁾
CR	Pilot signal (only on CR)	ISO 6149	M14 x 1.5; 11.5 deep	420 O
PR	Pilot signal (only on PR)	ISO 6149	M14 x 1.5; 11.5 deep	420 O
H3 to H6	Pilot signal (only on H3, H4, H5 and H6)	ISO 6149	M14 x 1.5; 11.5 deep	100 O
X	Pilot signal	ISO 6149 ⁵⁾	M14 x 1.5; 11.5 deep	420 O
DP, DP₁	Pilot pressure (only on DP)	ISO 6149	M14 x 1.5; 11.5 deep	420 O
M	Measuring control pressure	ISO 6149 ⁵⁾	M14 x 1.5; 12 deep	420 X
M_A	Measuring pressure A	ISO 6149 ⁵⁾	M14 x 1.5; 12 deep	420 X
M_S	Measuring suction pressure (only A15VSO)	ISO 6149 ⁵⁾	M14 x 1.5; 12 deep	3 X
P	External control pressure (ordering code digit 8 version B or C = with external control pressure supply)	ISO 6149 ⁵⁾	M14 x 1.5; 11.5 deep	50 O
	Port P without function (ordering code digit 8 version A = without external control pressure supply)	ISO 6149 ⁷⁾	M18 x 1.5; 14.5 deep	420 X

1) Center bore according to DIN 332 (thread according to DIN 13)
 2) Observe the general instructions on page 58 for the maximum tightening torques.
 3) Momentary pressure spikes may occur depending on the application. Keep this in mind when selecting measuring devices and fittings.
 4) Metric fastening threads is a deviation from standard

5) The spot face can be deeper than specified in the appropriate standard.
 6) Depending on installation position, T₁, T₂ or T₃ must be connected (see also installation instructions on pages 56 and 57).
 7) O = Must be connected (plugged on delivery)
 X = Plugged (in normal operation)

▼ **LR – Power controller, fixed setting**

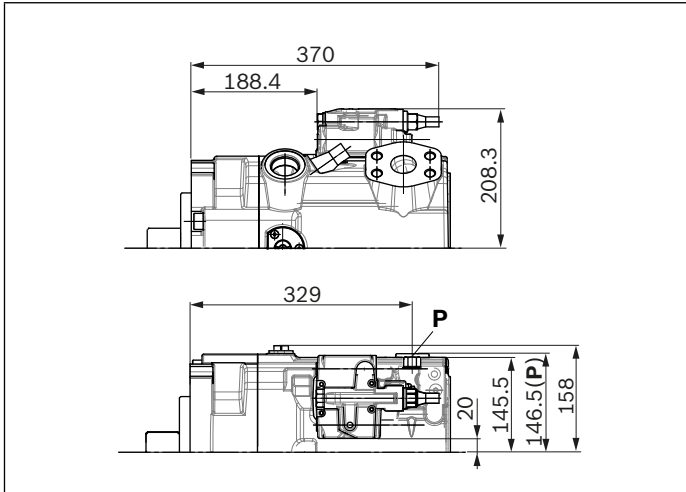

▼ **L4 – Power controller, electric-proportional override**

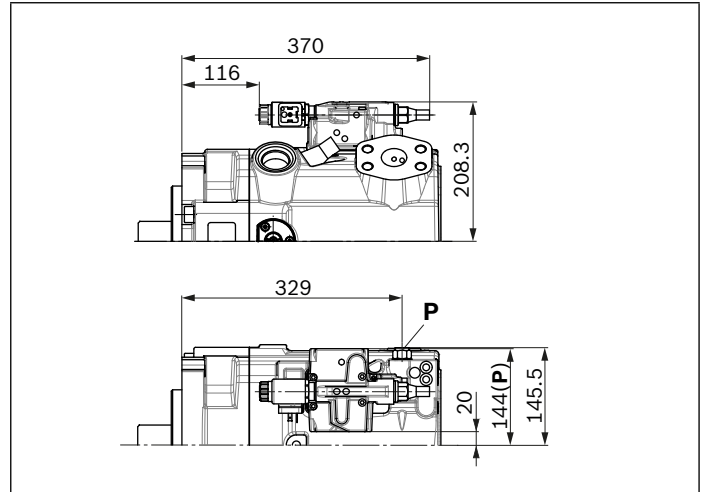

▼ **CR – Power controller, hydraulic-proportional override, high pressure, with stop**

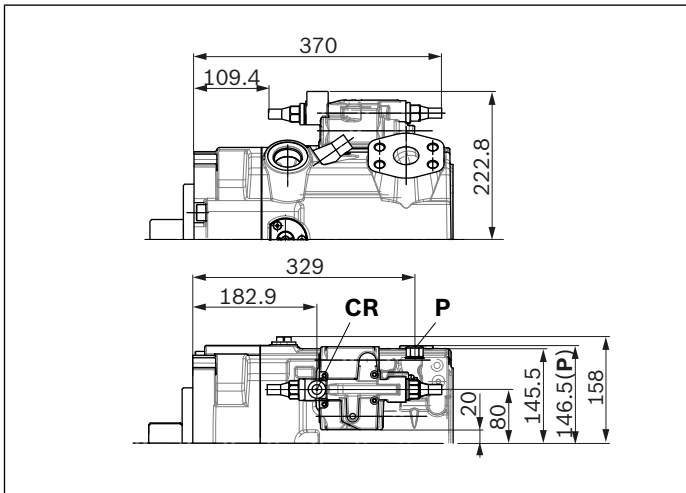

▼ **PR – Power controller, hydraulic-proportional override, high pressure, without stop**

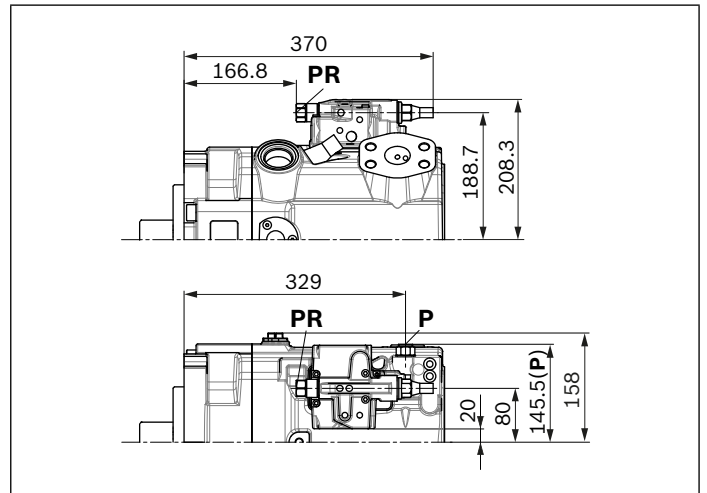

▼ **E2/E6 – Stroke control electric-proportional**

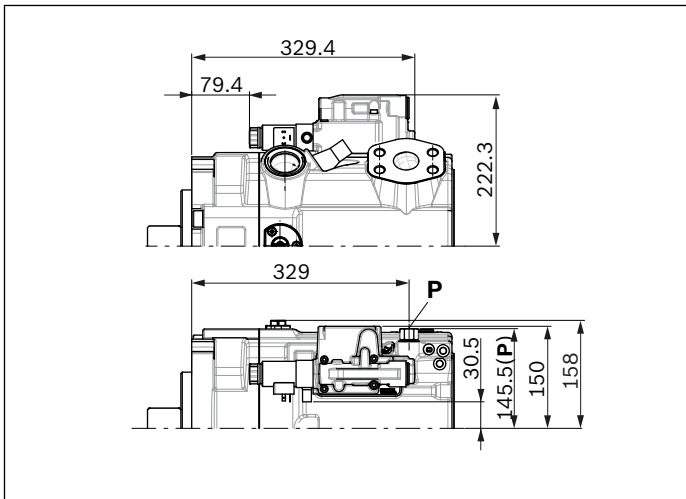

▼ **H3/4/5/6 – Stroke control, hydraulic-prop., pilot pressure**

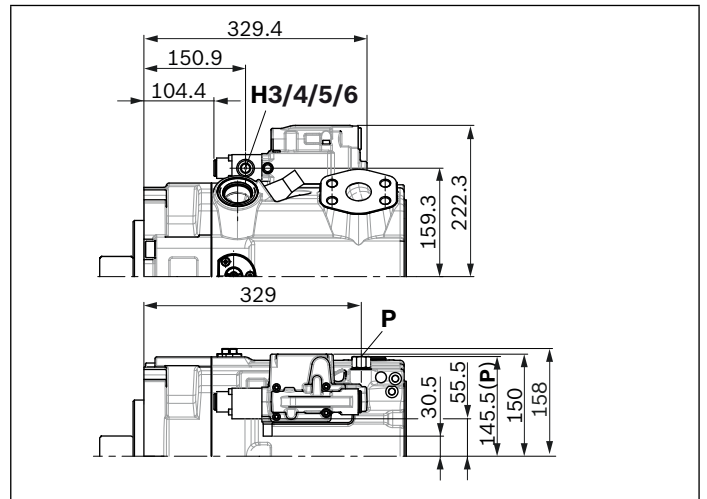

Note

All controllers described with shuttle valve in **P** (some contrary to standard as per ordering code digit 08)

▼ **DR – Pressure controller, fixed setting**

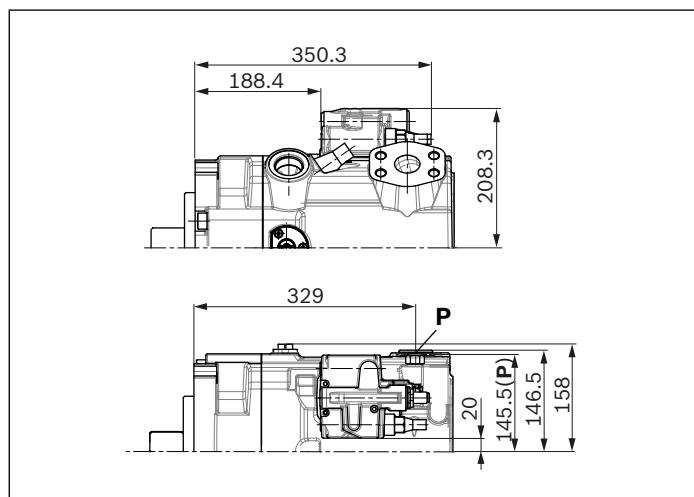

▼ **LRDRSO – Power controller with pressure controller and load sensing, fixed setting**

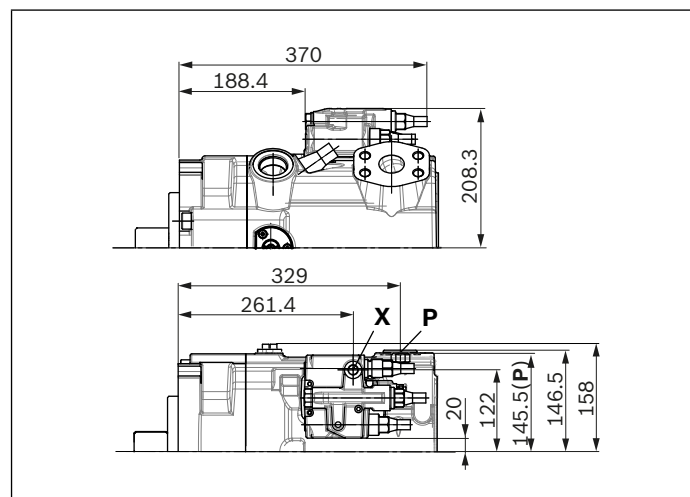

▼ **DG – Pressure controller, hydraulic, remote controlled**

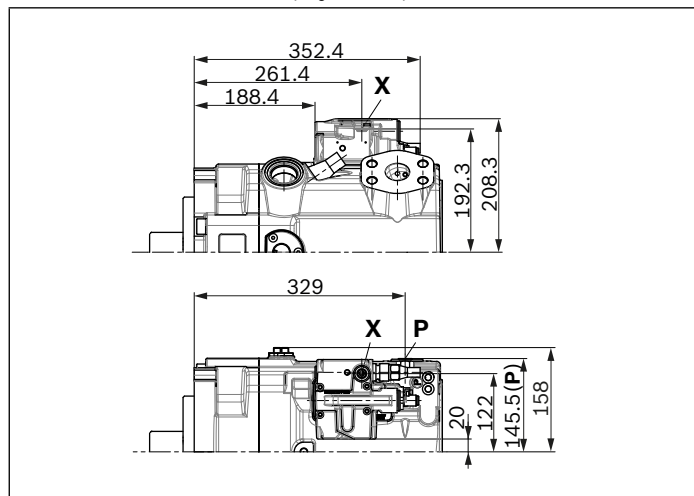

▼ **DP – Pressure controller, for parallel operation**

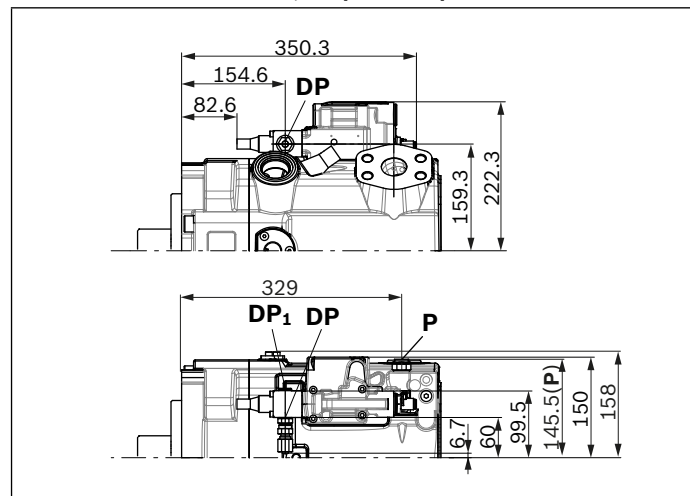

Note

All controllers described with shuttle valve in **P** (some contrary to standard as per ordering code digit 08)

Through drives dimensions

Flange SAE J744			Hub for splined shaft ²⁾			Availability over sizes					Short code
Diameter	Attachment ¹⁾	Designation	Diameter		Designation	110	145	175	210	280	
82-2 (A)	⊗	A3	5/8 in	9T 16/32DP	S2	○	○	●	●	●	A3S2
101-2 (B)	⊗	B3	7/8 in	13T 16/32DP	S4	○	○	●	●	●	B3S4
			1 in	15T 16/32DP	S5	○	○	●	●	●	B3S5

● = Available ○ = On request

▼ 82-2 (A)

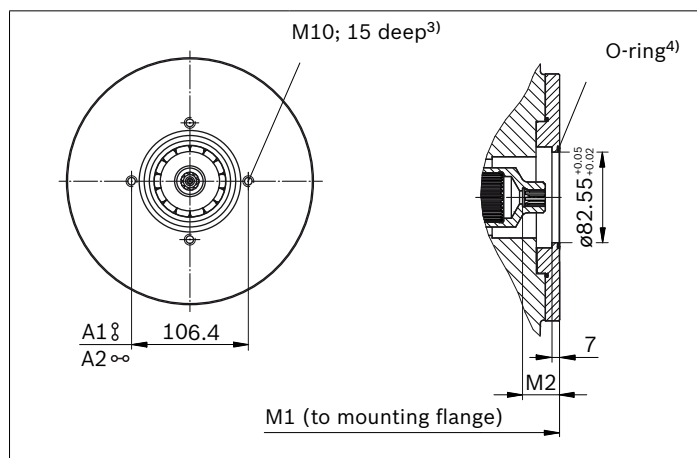

A3S2	NG	M1	M2
without charge pump	175	340.5	33.8
	210	357.8	33.8
	280	400	33.8
with charge pump	175	389.5	33.8
	210	406.8	33.8
	280	438	33.8

▼ 101-2 (B)

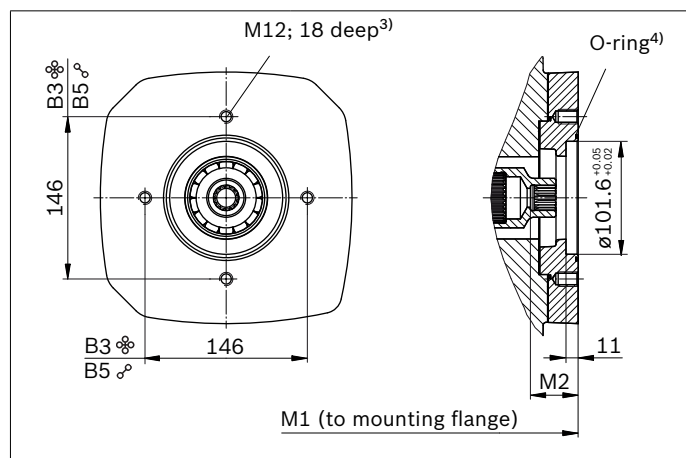

B3S4, B3S5	NG	M1	M2
without charge pump	175	354.5	43
	210	371.8	43
	280	414	43
with charge pump	175	403.5	43
	210	420.8	43
	280	452	43

1) Mounting drillings pattern viewed on through drive with control at top
 2) According to ANSI B92.1a, 30° pressure angle, flat root, side fit, tolerance class 5

3) Thread according to DIN 13, observe the general instructions on page 58 for the maximum tightening torques.
 4) O-ring included in the scope of supply

Flange SAE J744			Hub for splined shaft			Availability over sizes					Short code
Diameter	Attachment ¹⁾	Designation	Diameter	Designation	110	145	175	210	280		
127-2 (C)	☼	C3	1 1/4 in 14T 12/24DP ²⁾	S7	○	○	●	●	●	C3S7	
			1 1/2 in 17T 12/24DP ²⁾	S9	○	○	○	○	●	C3S9	
152-4 (D)	☼☼	D4	W45x2x21x9g ³⁾	A1	○	○	○	○	○	D4A1	
			W50x2x24x9g ³⁾	A2	○	○	○	○	○	D4A2	
165-4 (E)	☼☼	E4	W50x2x24x9g ³⁾	A2	●	●	●	●	●	E4A2	
			W60x2x28x9g ³⁾	A4	○	○	○	○	●	E4A4	

● = Available ○ = On request

▼ **127-2 (C)**

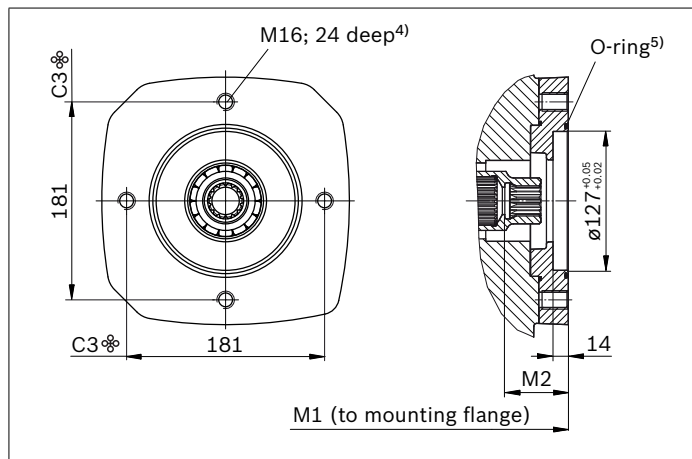

▼ **165-4 (E)**

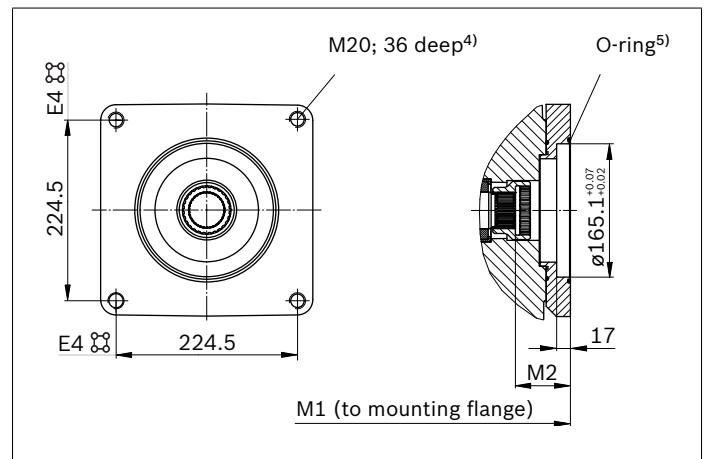

C3S7	NG	M1	M2
without charge pump	175	354.5	58.1
	210	371.8	58.1
	280	414	58.1
with charge pump	175	403.5	58.1
	210	420.8	58.1
	280	452	58.1

E4A2	NG	M1	M2
without charge pump	175	363.5	58.1
	210	380.8	58.1
	280	423	58.1
with charge pump	175	412.5	58.1
	210	429.8	58.1
	280	461	58.1

C3S9	NG	M1	M2
without charge pump	280	414	63.8
with charge pump	280	452	63.8

E4A4	NG	M1	M2
without charge pump	280	423	68
with charge pump	280	461	68

1) Mounting drillings pattern viewed on through drive with control at top.
2) According to ANSI B92.1a, 30° pressure angle, flat root, side fit, tolerance class 5

3) According to DIN 5480
4) Thread according to DIN 13, observe the general instructions on page 58 for the maximum tightening torques.
5) O-ring included in the scope of supply

Flange ISO3019-2 (metric)			Hub for splined shaft ²⁾			Availability over sizes					Short code
Diameter	Attachment ¹⁾	Designation	Diameter		Designation	110	145	175	210	280	
80-2		K3	3/4 in	11T 16/32DP	S3	○	○	○	○	○	K3S3
		K5	3/4 in	11T 16/32DP	S3	○	○	○	●	○	K5S3
100-2		L5	7/8 in	13T 16/32DP	S4	○	○	○	○	○	L5S4

● = Available ○ = On request

▼ 80-2

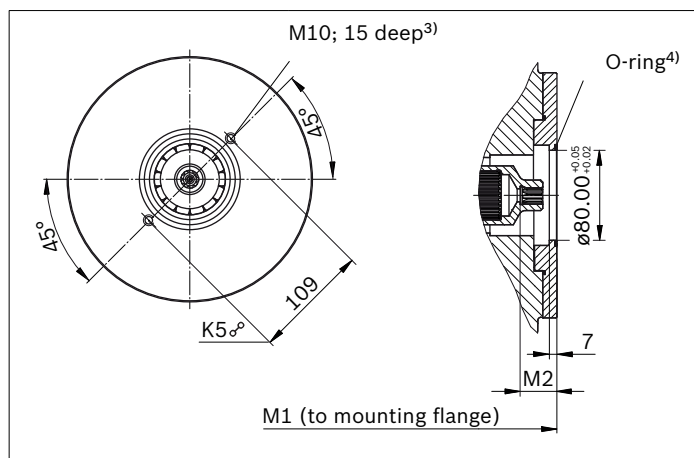

K5S3	NG	M1	M2
without charge pump	210	357.8	40
with charge pump	210	395.8	40

1) Mounting drillings pattern viewed on through drive with control at top.
2) According to ANSI B92.1a, 30° pressure angle, flat root, side fit, tolerance class 5

3) Thread according to DIN 13, observe the general instructions on page 58 for the maximum tightening torques.
4) O-ring included in the scope of supply

Flange ISO3019-2 (metric)			Hub for splined shaft ²⁾			Availability over sizes					Short code
Diameter	Attachment ¹⁾	Designation	Diameter		Designation	110	145	175	210	280	
180-4		R4	1 1/2 in	17T 12/24DP	S9	○	○	○	○	●	R4S9
			1 3/4 in	13T 8/16DP	T1	○	○	○	○	○	R4T1

● = Available ○ = On request

▼ **180-4**

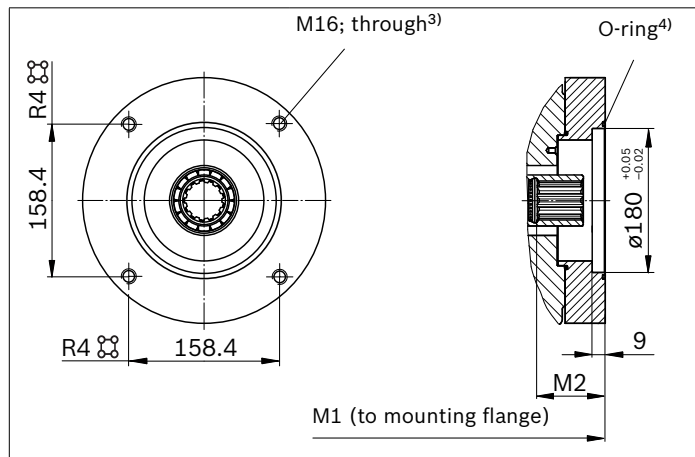

R4S9	NG	M1	M2
without charge pump	280	419	70
with charge pump	280	467	70

1) Mounting drillings pattern viewed on through drive with control at top
2) According to ANSI B92.1a, 30° pressure angle, flat root, side fit, tolerance class 5

3) Thread according to DIN 13, observe the general instructions on page 58 for the maximum tightening torques.
4) O-ring included in the scope of supply

Overview of attachment options

Through drive ¹⁾			Attachment options – 2nd pump				
Flange SAE J744	Hub for splined shaft	Short code	A15VSO/10 A15VLO/10 NG (shaft)	A10VSO/31 NG (shaft)	A10VSO/32 NG (shaft)	A10VO/52 and 53 NG (shaft)	External gear pump
82-2 (A)	5/8 in	A_S2	–	–	–	10, 18 (U)	Series F ²⁾
101-2 (B)	7/8 in	B3S4	–	–	–	28 (R, S); 45 (U, W)	Series N ²⁾
	1 in	B3S5	–	–	–	45 (R, S); 60, 63 (U, W)	PGH4
127-2 (C)	1 1/4 in	C3S7	–	–	–	85, 100 (U, W)	–
	1 1/2 in	C3S9	–	–	–	85, 100 (S)	PGH5
152-4 (D)	W45	D4A1	110 (A1)	–	–	–	–
	W50	D4A2	145 (A2)	–	–	–	–
165-4 (E)	W50	E4A2	175; 210 (A2)	–	–	–	–
	W60	E4A4	280 (A4)	–	–	–	–
Flange (metric)	Hub for splined shaft	Short code	A15VSO/10 A15VLO/10 NG (shaft)	A10VSO/31 NG (shaft)	A10VSO/32 NG (shaft)	A10VO/52 and 53 NG (shaft)	External gear pump
80-2	3/4 in	K_S3	–	18 (S, R)	–	10 (S)	–
100-2	7/8 in	L5S4	–	28 (S, R)	–	–	–
160-4	1 1/4 in	P4S7	–	–	71 (S, R)	–	–
180-4	1 1/2 in	R4S9	–	–	100 (S)	–	–
	1 3/4 in	R4T1	–	140 (S)	140, 180 (R)	–	–
125-4	1 in	M4S5	–	–	45 (S, R)	–	–
140-4	W40	N4Z9	–	–	–	–	–

1) Additional through drives are available on request

2) Bosch Rexroth recommends special versions of the external gear pumps. Please contact us.

Combination pumps A15V... + A15V...

Total length A

A15VSO (1st pump)	A15VSO (2nd pump)					A15VLO (2nd pump)		
	NG110	NG145	NG175	NG210	NG280	NG175	NG210	NG280
	D4A1	D4A2	E4A2	E4A2	E4A4	E4A2	E4A2	E4A4
NG145	–	656	–	–	–	–	–	–
NG175	648.5	673.5	691	–	–	758	–	–
NG210	665.8	690.8	708.3	725.6	–	775.3	792.6	–
NG280	699	733	750.5	767.8	810	817.5	834.8	866

A15VLO (1st pump)	A15VSO (2nd pump)					A15VLO (2nd pump)		
	NG110	NG145	NG175	NG210	NG280	NG175	NG210	NG280
	D4A1	D4A2	E4A2	E4A2	E4A4	E4A2	E4A2	E4A4
NG175	697.5	722.5	740	–	–	807	–	–
NG210	714.8	739.8	757.3	774.6	–	824.3	841.6	–
NG280	737	771	788.5	805.8	848	855.5	872.8	904

By using combination pumps, it is possible to have independent circuits without the need for splitter gearboxes. When ordering combination pumps, the type designations of the 1st and 2nd pumps must be linked by a “+”.

Order example:

A15VSO280LRDRA00/10MRVE4A41SE4A40-0+

A15VSO280LRDRA00/10MRVE4A41SU0000-0

A tandem pump consisting of two equal sizes is permissible without additional supports assuming that the dynamic mass acceleration does not exceed maximum 10 g (= 98.1 m/s²). For combination pumps consisting of more than two pumps, the mounting flange must be rated for the permissible mass torque.

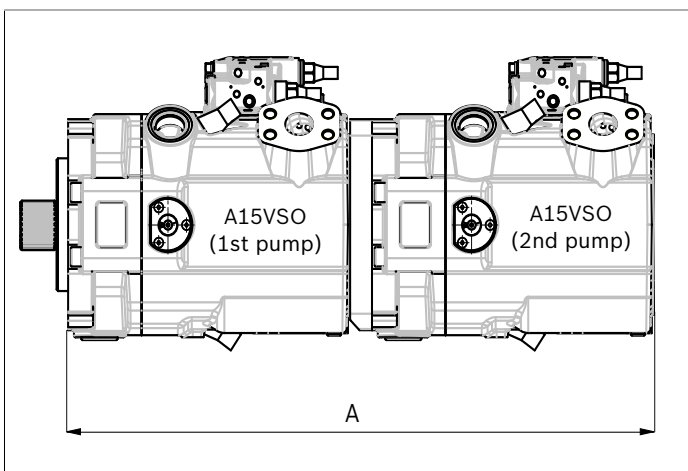

Connector for solenoids

HIRSCHMANN DIN EN 175 301-803-A /ISO 4400

without bidirectional suppressor diode _____H

Type of protection according to DIN/EN 60529 _____ IP65

The seal in the cable fitting is suitable for lines of diameter 4.5 mm to 10 mm.

The line connector box is not included in the scope of supply.

This can be supplied by Bosch Rexroth on request (material number: R902602623).

Changing connector orientation

If necessary, you can change the connector orientation by turning the solenoid housing.

To do this, proceed as follows:

- ▶ Loosen the mounting nut **(1)** of the solenoid. To do this, turn the mounting nut **(1)** one turn counter-clockwise.
 - ▶ Turn the solenoid body **(2)** to the desired orientation.
 - ▶ Retighten the mounting nut.
- Tightening torque: 5+1 Nm.
(size WAF 26, 12-sided DIN 3124)

On delivery, the connector orientation may differ from that shown in the brochure or drawing.

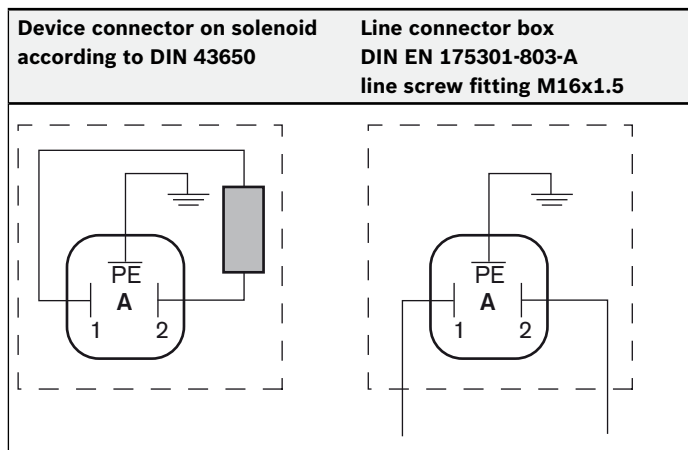
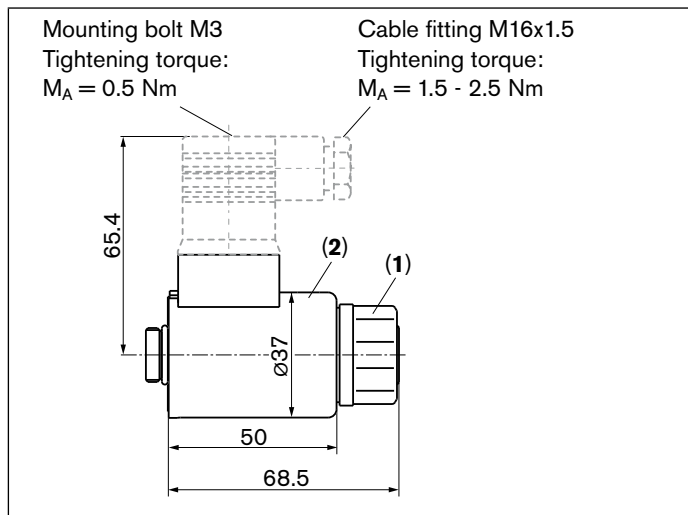

Installation instructions

General

During commissioning and operation, the axial piston unit must be filled with hydraulic fluid and air bled. This must also be observed following a relatively long standstill as the axial piston unit may drain back to the reservoir via the hydraulic lines.

Particularly in the installation position "drive shaft upwards" filling and air bleeding must be carried out completely as there is, for example, a danger of dry running. The case drain fluid in the pump housing must be directed to the reservoir via the highest available drain port (**T**₁, **T**₂, **T**₃). For combinations of multiple units, the case drain fluid must be drained off at each pump. If a shared reservoir line is used for this purpose, make sure that the case pressure in each pump is not exceeded. In the event of pressure differences at the drain ports of the units, the shared drain line must be changed so that the minimum permissible case pressure of all connected units is not exceeded in any situation. If this is not possible, separate drain lines must be laid if necessary.

To achieve favorable noise values, decouple all connecting lines using elastic elements and avoid above-reservoir installation.

In all operating conditions, the suction and drain lines must flow into the reservoir below the minimum fluid level. The permissible suction height h_s results from the overall loss of pressure; it must not, however, be higher than $h_{s \max} = 800$ mm. The minimum suction pressure at port **S** must also not fall below 0.8 bar absolute (without charge pump) or 0.7 bar absolute (with charge pump) during operation and during a cold start.

When designing the reservoir, ensure adequate space between the suction line and the drain line. This prevents the heated, return flow from being drawn directly back into the suction line.

Note

In certain installation positions, an influence on the control characteristics can be expected. Gravity, dead weight and case pressure can cause minor shifts in control characteristics and changes in response time.

Installation position

See examples **1** to **9** below.

Additional installation positions are available upon request.
Recommended installation positions: **1** and **2**

Below-reservoir installation (standard)

Below-reservoir installation means that the axial piston unit is installed outside of the reservoir below the minimum fluid level.

Installation position	Air bleed	Filling
1	T ₁	S + T ₁

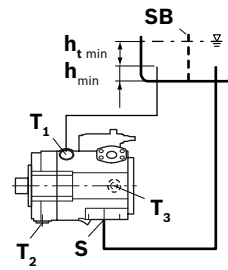

2	T ₂	S + T ₂
----------	-----------------------	----------------------------------

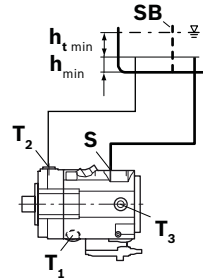

3	T ₂	S + T ₂
----------	-----------------------	----------------------------------

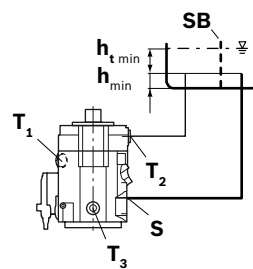

Key

L	Filling / air bleed
S	Suction port
T	Drain port
SB	Baffle (baffle plate)
h_{t min}	Minimum required immersion depth (200 mm)
h_{min}	Minimum required distance to reservoir bottom (100 mm)
h_{ES min}	Minimum necessary height to prevent the axial piston unit from draining (25 mm)
h_{S max}	Maximum permissible suction height (800 mm)

Above-reservoir installation

Above-reservoir installation means that the axial piston unit is installed above the minimum fluid level of the reservoir. To prevent the axial piston unit from draining in position 6, the height difference $h_{ES\ min}$ at port **T₂** must be at least 25 mm. Observe the maximum permissible suction height $h_{S\ max} = 800\ mm$.

Installation position	Air bleed	Filling
<p>4</p>	F	T₁ (F)
<p>5</p>	F	T₂ (F)
<p>6</p>	F	T₂ (F)

Inside-reservoir installation

Inside-reservoir installation is when the axial piston unit is installed in the reservoir below the minimum fluid level. The axial piston unit is completely below the hydraulic fluid.

If the minimum fluid level is equal to or below the upper edge of the pump, see chapter "**Above-reservoir installation**".

Axial piston units with electric components (e.g. electric controls, sensors) must not be installed in a reservoir below the fluid level.

Exception

Installation of the pump with E2/E6 control only with HIRSCHMANN connector and if mineral hydraulic fluids are used and the fluid temperature in the reservoir does not exceed 80 °C

Installation position	Air bleed	Filling
<p>7</p>	Via the highest available port T₁	Automatically via the open port T₁ due to position below hydraulic fluid level
<p>8</p>	Via the highest available port T₂	Automatically via the open port T₂ due to position below hydraulic fluid level
<p>9</p>	Via the highest available port T₂	Automatically via the open port T₂ due to position below hydraulic fluid level

General instructions

- ▶ The A15VSO and A15VLO pumps are designed to be used in open circuits.
- ▶ The project planning, installation and commissioning of the axial piston unit requires the involvement of skilled person.
- ▶ Before using the axial piston unit, please read the corresponding instruction manual completely and thoroughly. If necessary, these can be requested from Bosch Rexroth.
- ▶ During and shortly after operation, there is a risk of burns on the axial piston unit and especially on the solenoids. Take appropriate safety measures (e. g. by wearing protective clothing).
- ▶ Depending on the operating conditions of the axial piston unit (operating pressure, fluid temperature), the characteristic may shift.
- ▶ Service line ports:
 - The ports and fastening threads are designed for the specified maximum pressure. The machine or system manufacturer must ensure that the connecting elements and lines correspond to the specified application conditions (pressure, flow, hydraulic fluid, temperature) with the necessary safety factors.
 - The service line ports and function ports can only be used to accommodate hydraulic lines.
- ▶ The data and notes contained herein must be adhered to.
- ▶ Before finalizing your design, request a binding installation drawing.
- ▶ Not all variants of the product are approved for use in safety functions according to ISO 13849. Please consult the responsible contact person at Bosch Rexroth if you require reliability parameters (e.g. $MTTF_d$) for functional safety.
- ▶ Pressure controllers are not backups against pressure overload. A separate pressure-relief valve is to be provided in the hydraulic system.
- ▶ The following tightening torques apply:
 - Fittings:
 - Observe the manufacturer's specifications regarding the tightening torques of the fittings used.
 - Mounting bolts:
 - For mounting bolts with metric ISO thread according to DIN 13 or with thread according to ASME B1.1, we recommend checking the tightening torque in individual cases in accordance with VDI 2230.
 - Female threads in the axial piston unit:
 - The maximum permissible tightening torques $M_{G \max}$ are maximum values for the female threads and must not be exceeded. For values, see the following table.
 - Threaded plugs:
 - For the metallic threaded plugs supplied with the axial piston unit, the required tightening torques of threaded plugs M_V apply. For values, see the following table.

Ports		Maximum permissible tightening torque of the female threads $M_{G \max}$	Required tightening torque of the threaded plugs M_V	WAF hexagon socket of the threaded plugs
Standard	Thread size			
ISO 6149	M14 x 1,5	80 Nm	45 Nm	6 mm
	M18 x 1,5	140 Nm	70 Nm	8 mm
	M33 x 2	540 Nm	310 Nm	17 mm
	M42 x 2	720 Nm	330 Nm	22 mm

Bosch Rexroth AG
Mobile Applications
An den Kelterwiesen 14
72160 Horb a.N., Germany
Tel. +49 7451 92-0
info.ma@boschrexroth.de
www.boschrexroth.com

© This document, as well as the data, specifications and other information set forth in it, are the exclusive property of Bosch Rexroth AG. It may not be reproduced or given to third parties without its consent. The data specified above only serve to describe the product. No statements concerning a certain condition or suitability for a certain application can be derived from our information. The information given does not release the user from the obligation of own judgment and verification. It must be remembered that our products are subject to a natural process of wear and aging.

Bosch Rexroth AG

Mobile Applications
An den Kelterwiesen 14
72160 Horb a.N., Germany
Tel. +49 7451 92-0
info.ma@boschrexroth.de
www.boschrexroth.com

© This document, as well as the data, specifications and other information set forth in it, are the exclusive property of Bosch Rexroth AG. It may not be reproduced or given to third parties without its consent. The data specified above only serve to describe the product. No statements concerning a certain condition or suitability for a certain application can be derived from our information. The information given does not release the user from the obligation of own judgment and verification. It must be remembered that our products are subject to a natural process of wear and aging.